

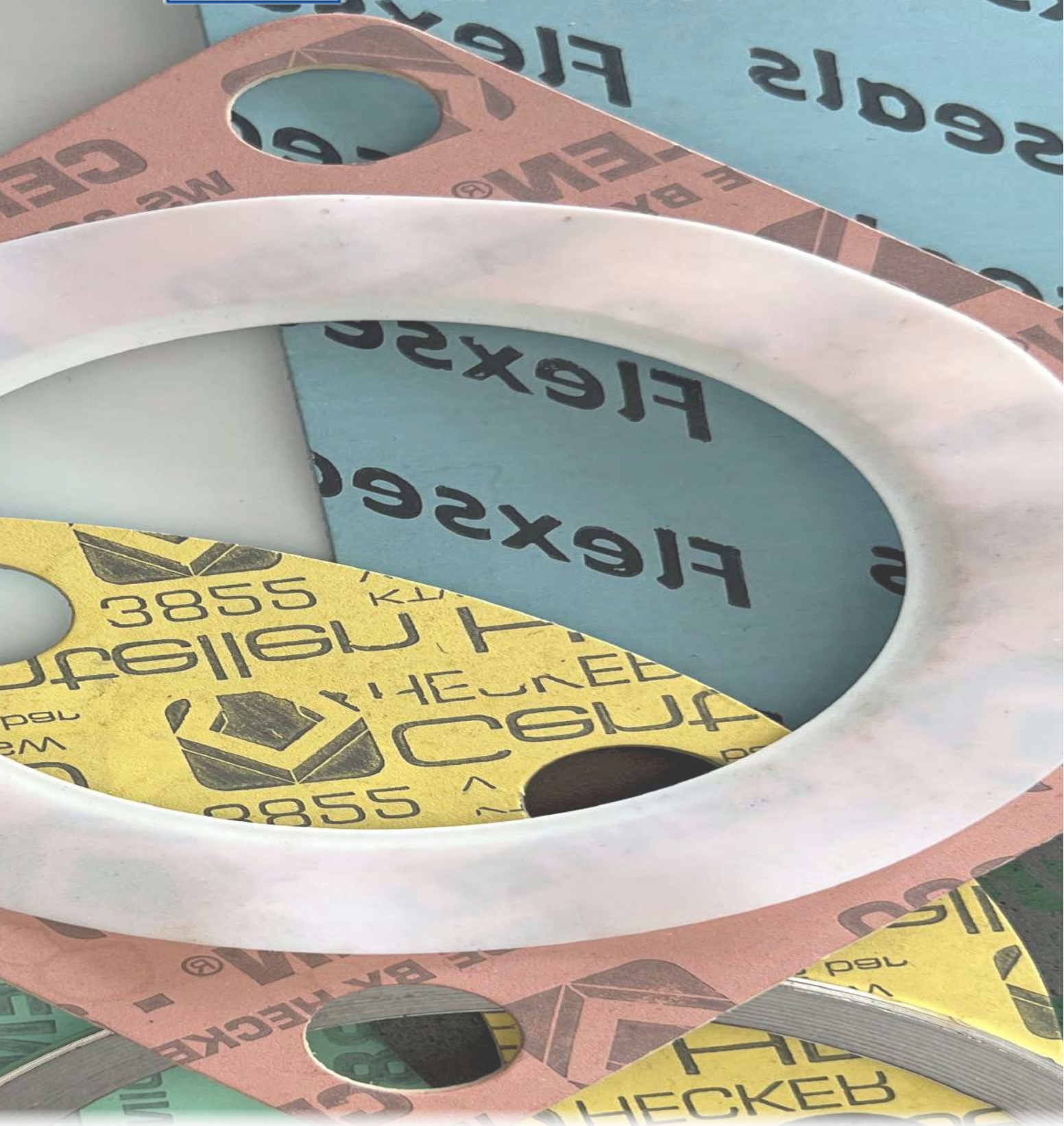

ONE LEVEL

王利企業有限公司



www.onelevel.com.tw



ONE LEVEL
王利企業有限公司

公司簡介

王利企業有限公司創立於民國 83(1994) 年，專業製造各式各樣密封墊片及密封材料加工，多年來秉持著三大之原則為 S.M.S。

專業 (Specialized)、製造 (Manufacture)、服務 (Service)

為本公司長久以來的經營理念，因此累積十來年的製造設計之技術，及生產應用經驗與良好的品質管理，因應市場上的需求及產業不斷地求新求變，快速生產並將合格率提高及現今環保的重要性納入公司生產之相關密封墊片。

本公司擁有完整的密封墊片生產設備，多樣性的密封墊片庫存，亞洲獨家代理德國 HECKER 非石棉墊片、台灣獨家代理義大利 FMI Sichem 非石棉墊片、複合式鐵氟龍墊片及石墨墊片，亦供應多樣密封墊片產品。

產業 (品) 遍及各大鋼鐵廠、造船廠、煉油廠、石化廠、知名科技公司及相關大型工程等。

顧客至上 • 服務第一

是王利公司最大的優點也是本公司員工的一貫信念，也讓本公司日漸茁壯。

總經理 王進忠

營業項目

本公司擁有完整的密封墊生產設備，豐富的密封墊原料庫存及相關歐盟認證產品！

1. 非石棉雙面抗黏密封墊片、非石棉夾金屬網墊片
2. 石墨墊片、石墨環、石墨帶、夾金屬網石墨墊片、金屬平板增強石墨墊片、金屬沖刺網石墨墊片
3. 金屬渦卷墊片、齒形複合墊片、金屬包覆墊片、金屬波紋墊片、金屬環、中空金屬環
4. 純四氟墊片、純四氟包覆墊片、膨體四氟墊片、膨體四氟條 & 帶、改性四氟墊片
5. 各種橡膠墊片及 O 形環、油封、凸環墊片
6. 耐油紙墊片、軟木橡膠墊片
7. 各類材質編織盤根
8. 防火保溫材料（玻璃纖維、陶瓷纖維、碳纖維、雲母）、絕緣組、安全防護套等
9. 耐超高溫墊片
10. 絕緣組

均可於短時間內供應客戶所需要之形狀尺寸。



目錄

1 非石棉板系列 1 - 8

2 石墨系列 9 - 13

3 金屬 / 半金屬系列 14 - 31

4 鐵氟龍系列 (PTFE) 32 - 40

5 橡膠系列 41 - 48

6 耐油紙 / 軟木系列 49 - 50

7 盤根系列 51 - 52

8 防火保溫系列 53

9 雲母系列 54 - 57

10 絕緣系列 58 - 60

非石棉板系列

非石棉板狀密合墊料

Non-asbestos Sheet Gasket

是由有機混合物纖維和橡膠粘合劑製成，提供優異的耐化學性、耐熱性、多功能化學和物理性質，因此具備最強的多功能性。不同的墊料有不同的填充物材料可共同使用，與大多數化學品、溫度和壓力作用時能保證提供出色的密封性能。墊片材使用基於合成的填料纖維、礦物纖維、芳綸纖維和碳纖維，以確保最佳的可靠性和耐用性。

型號 FLEXSEALS®		AF163	AF240	AF280M	AF330
顏色					
組成		NBR/SBR 有機纖維	NBR 有機纖維	NBR 有機纖維 金屬絲網	NBR 高品質礦物 芳綸纖維
密度 (g/cm ³) DIN28090-2		1.7~2.1	1.6~1.9	1.9~2.2	1.7~2.0
最高連續作業溫度 (°C)		140	140	250	330
最高極限作業溫度 (°C)		210	350	400	450
最高作業工作壓力 (Mpa)		7	10	12	12
洩漏率 (mg*s-1*m-1) DIN 3535-6		0.1	0.1	0.08	0.04
應力鬆弛 (Mpa) 16h/175°C DIN 52913		20	20	30	32
壓縮率 (%)ASTM F 36-J		5~15	5~15	5~15	5~15
恢復率 (%)ASTM F 36-J		50	50	50	50
耐流體性能	IRM 903 試驗油 5h/150°C max(%) ASTM F 146	10	5	3	3
	FUEL B 燃料油 5h/23°C max(%) ASTM F 146"	15	5	5	5
尺寸規格	長度 * 寬度 (mm)	1500*1500	1500*1500	1500*1500	1500*1500
	厚度 (mm)	1500*3000 0.5~5.0	1500*3000 0.5~5.0	1500*3000 0.5~5.0	1500*3000 0.5~5.0
公差	長度 * 寬度 (mm)	+/-50	+/-50	+/-50	+/-50
	厚度 (%)	+/-10	+/-10	+/-10	+/-10

非石棉板系列

非石棉板狀密封墊料

厚度 2mm

AF163

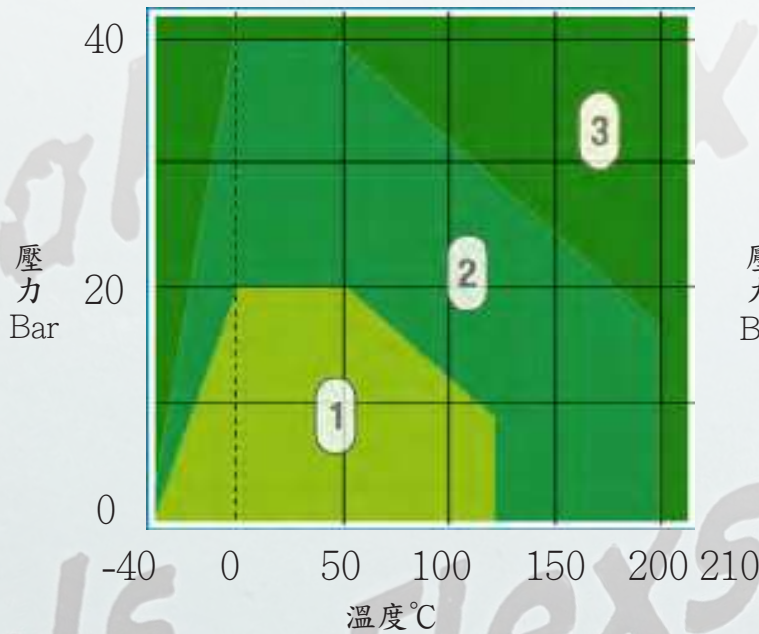

AF240

DVGW

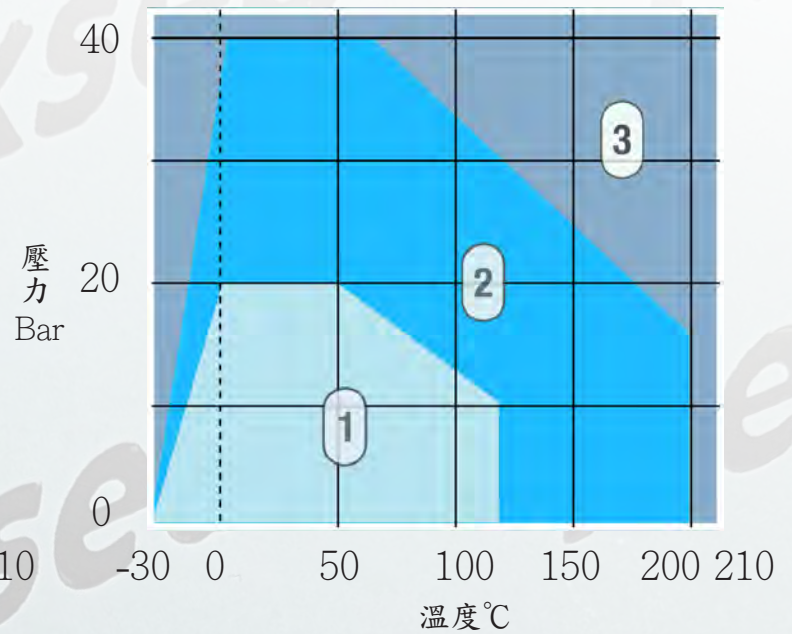

AF280M

DVGW

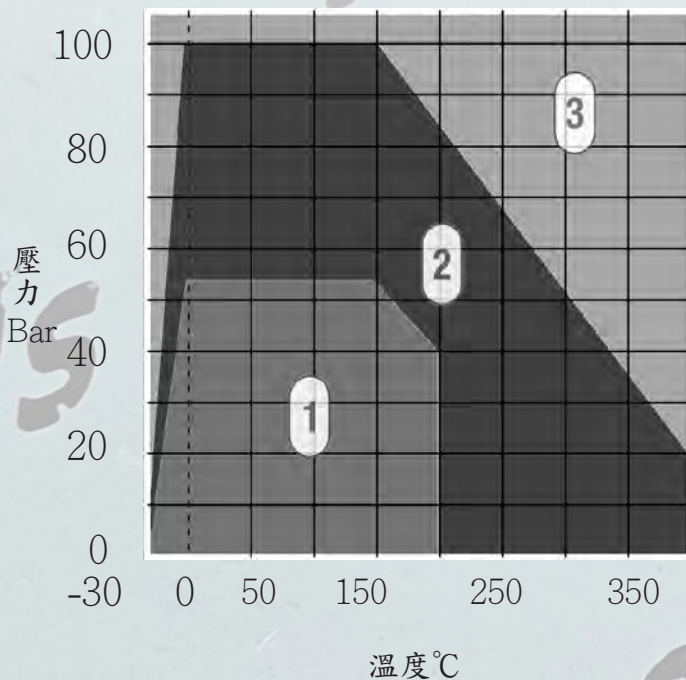

AF330

FIRE SAFE

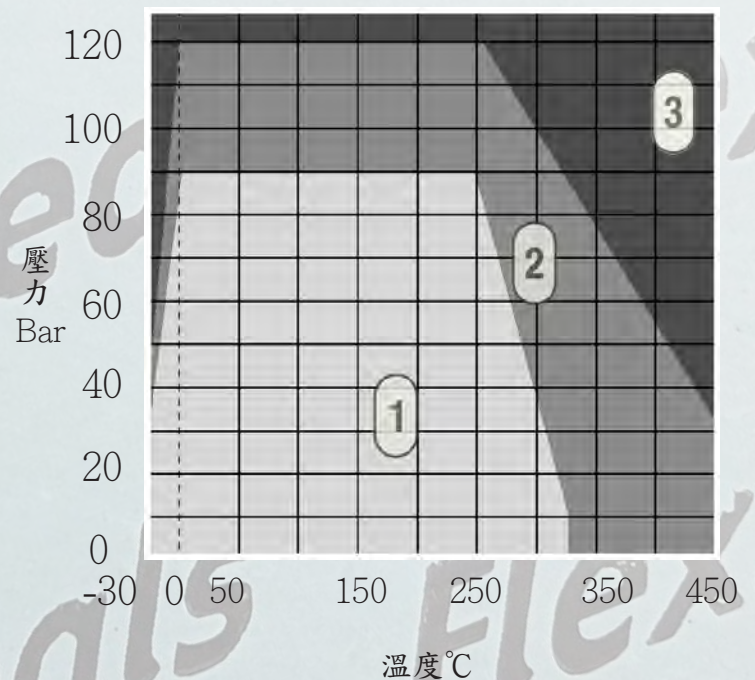

1. 適用區域 2. 可以使用區域 3. 需再經測試區域

非石棉墊料化學兼容性指南

● 適用 ● 不適用 ● 取決於操作條件

英文名稱	中文名稱	AF163	AF240	AF280M	AF330
Acetic acid 100%	乙酸100%	●	●	●	●
Acetone	丙酮	●	●	●	●
Acetylene	乙炔	●	●	●	●
Air	空氣	●	●	●	●
Aluminium chloride	氯化鋁	●	●	●	●
Ammonia	氨	●	●	●	●
Ammonium hydrogenphospate	氫氧化銨	●	●	●	●
Barium chloride	氯化鋇	●	●	●	●
Benzene	苯	●	●	●	●
Boric cid	硼酸	●	●	●	●
Calcium hydroxide	氫氧化鈣	●	●	●	●
Carbon dioxide	二氧化碳	●	●	●	●
Copper sulphate	硫酸銅	●	●	●	●
Crude oil	原油	●	●	●	●
Cyclohexanol	環己醇	●	●	●	●
Cyklohexanon	氟喹啉酮	●	●	●	●
Di-butyl phtalato	丁酸丁酯	●	●	●	●
Ethyl ether	乙醚	●	●	●	●
Ethylen	乙烯	●	●	●	●
Ethylene glycol	乙二醇	●	●	●	●
Formic acid 10%	甲酸10%	●	●	●	●
Glycerine	甘油	●	●	●	●
Hydraulic oil(mineral)	液壓油(礦物)	●	●	●	●
Hydrogen chloride dry	氯化氫乾燥	●	●	●	●
Hydrochlorid acid 20%	鹽酸20%	●	●	●	●
Chlorine dry	氯幹	●	●	●	●
Chloroform	氯仿	●	●	●	●
Iso-Octane	異辛烷	●	●	●	●
Kerosene	煤油	●	●	●	●
Methylene chloride	二氯甲烷	●	●	●	●
Natural gas	天然氣	●	●	●	●
Nitric acid 20%	硝酸20%	●	●	●	●
Nitrogen	氮	●	●	●	●
Petrol	汽油	●	●	●	●
Petroleum	石油	●	●	●	●
Phenol	苯酚	●	●	●	●
Potable water	飲用水	●	●	●	●
Potassium cyanide	氰化鉀	●	●	●	●
Potassium iodide	碘化鉀	●	●	●	●
Saturated steam	飽和蒸汽	●	●	●	●
Silicon oil	矽油	●	●	●	●
Sodium carbonate	碳酸鈉	●	●	●	●
Sodium hydrogen carbonate	碳酸氫鈉	●	●	●	●
Sodium hydrogen sulphite	亞硫酸氫鈉	●	●	●	●
Sodium hyfoxide	氫氧化鈉	●	●	●	●
Sodium chloride	氯化鈉	●	●	●	●
Sodium sulphate	硫酸鈉	●	●	●	●
Sugar	糖	●	●	●	●
Sulphuric acid 65%	硫酸65%	●	●	●	●
Tartaic acid	吐溫酸	●	●	●	●
Tetrachlormethane	四氯甲烷	●	●	●	●
Toluene	甲苯	●	●	●	●
Transformer oil	變壓器油	●	●	●	●
Turpentine	松節油	●	●	●	●
Xylene	二甲苯	●	●	●	●

非石棉板系列

CENTELLEN® WS 3825

技術特點

WS 3825 是依照研光操作流程所製造。它是由芳綸纖維、無機纖維、芳綸產品的回收物料、礦物填料結合混和橡膠所組成。這些密封板具有絕佳的抗黏性及最薄的表面塗料厚度，並且不會改變它的化學特性。

產品特點

WS 3825 是我們的特級產品，在高度的抗壓強度和溫度 200°C 以下具有絕佳的氣密性。此產品是特別為衛浴產業、汙水處理工業和機械製造產業所研發的。

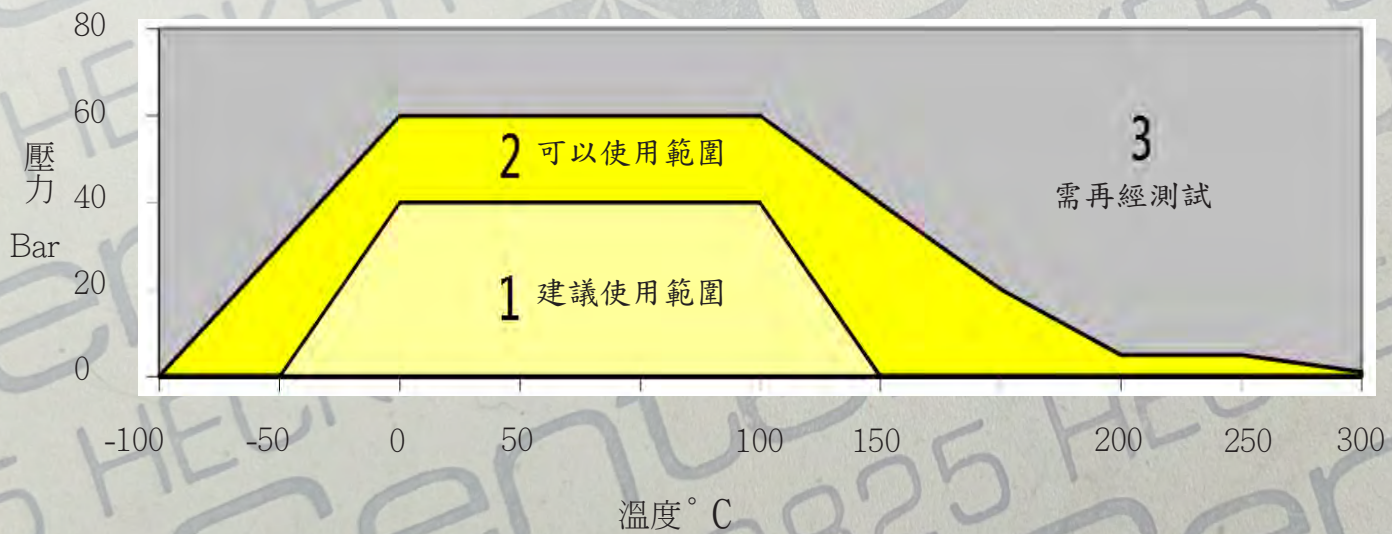

標準板

黃色

抗黏塗料 OBY2

標準交貨規格 1000*1500mm
1500*2000mm

可要求其他尺寸

厚度 0.5、1.0、1.5、2.0、3.0 mm

公差 厚度符合規格 (符合 DIN 28091-1)

長度 ±50 毫米，寬度 ±50 毫米

認證

DVGW

德國煤氣和水行業協會認證

BAM

德國氧氣認證

KTW

德國家庭用水認證

非石棉板系列

CENTELLEN® WS 3825

產品規格		數值	單位
密度		1.75	g/cm ³
壓縮性 ASTM F 36 J		9	%
回收率 ASTM F 36 J		55	%
熱壓縮 DIN 28090(2)		27	%
熱恢復 DIN 28090(2)		4	%
冷壓縮 DIN 28090(2)		8	%
冷恢復 DIN 28090(2)		5	%
洩漏率 DIN 28090(2)		0.01	mg/s*m
液體浸泡後厚度增加 ASTM F146	油 IRM 903 5 小時 / 150 °C	8	%
	燃油 B 5 小時 / 23 °C	10	%
壓縮力 50Mpa(16h 175°C) DIN 52913		25	Mpa
最大表面壓力 DIN 28090			
23°C		>200	N/mm ²
175°C		>200	
冷 / 熱壓縮 50 MPa	23 °C 時厚度減少	13	%
	300 °C 時厚度減少	28	%

對於化學物料的穩定性

高度穩定性

- ◎油或溶劑之類的碳氫化合物
- ◎醇、乙二醇、水溶劑、水和蒸氣至 150°C
- ◎氣體、酸性氣體除外

不適用於

- ◎強鹼 ◎強酸 ◎酮 ◎酯 ◎氯化溶劑

依照 SIN3754 的膨脹

於 ASTM3- 油 : < 10%

於 燃料 B : < 13%

於 水 : < 3%

非石棉板系列

CENTELLEN® WS 3820

WS 3820 是依照研光操作流程所製造的。除此之外它還涵蓋丁晴橡膠當作粘結劑。這些密封板擁有絕佳的抗粘性及最薄的表面厚度，並且不會改變它的化學特性。WS 3820 是我們的廣用性產品，可達高度機械穩定值；它的氣密度符合所有氣態供應產業的氣密度要求標準。

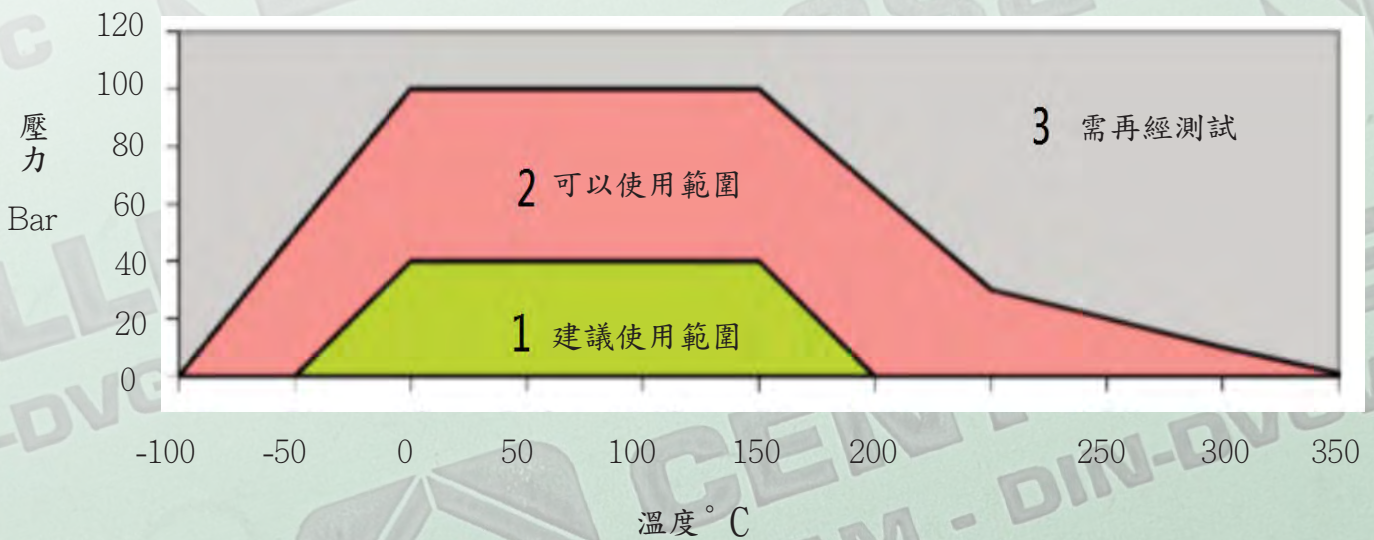

標準板

綠色

抗黏塗料 OBY2

標準交貨規格 1000*1500mm

1500*2000mm

可要求其他尺寸

厚度 0.5、1.0、1.5、2.0、3.0 mm

公差 厚度符合規格 (符合 DIN 28091-1)

長度 ±50 毫米，寬度 ±50 毫米

認證

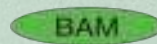

德國氧氣認證



德國家庭用水
並經過極為小生物 & 細菌檢驗測試



德國煤氣和水行業協會認證

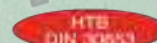

DVGW VP 401 燃氣防火安全



德國檢驗微量洩漏 & 排放

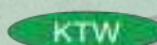

德國家庭用水認證

非石棉板系列

CENTELLEN® WS 3820

產品規格		數值	單位
密度		1.85	g/cm ³
壓縮性 ASTM F 36 J		10	%
回收率 ASTM F 36 J		60	%
熱壓縮 DIN 28090(2)		25	%
熱恢復 DIN 28090(2)		3	%
洩漏率 DIN 28090(2)		0.02	mg/s*m
液體浸泡後厚度增加 ASTM F146	油 IRM 903 5 小時 /150 °C	5	%
	燃油 B 5 小時 /23 °C	8	%
壓縮力 (16h 175°C) DIN 52913		30	Mpa
壓縮力 (16h 300°C) DIN 52913		25	Mpa
最大表面壓力 DIN 28090			
23°C		>200	N/mm ²
200°C		>200	
250°C		140	
冷 / 熱壓縮 50 MPa	23 °C 時厚度減少	10	%
	300 °C 時厚度減少	25	%

化學物料的穩定性

適用於

- ◎油或溶劑之類的碳氫化合物
- ◎醇、乙二醇、水溶液、水和高達 200°C 以下蒸汽
- ◎弱鹼液和有機酸

有限度的是用於

- ◎酮和酯
- ◎氯化溶劑
- ◎強鹼和無機酸

不適用於

- ◎氫氟酸
- ◎濃硝酸

石墨系列

石墨帶（背膠、無背膠）、石墨填料環

Flexible Graphite Sheet Tape& Ring

以高碳鱗片石墨經化學處理及高溫膨脹軋製而成的石墨原料製成各種捲箔、板帶、模成型環，有耐高溫、良好的導電及導熱性、潤滑性佳、抗酸鹼的特性。

適用範圍：

使用溫度範圍從 -200°C 至 550°C

最高使用壓力為 150bar。

石墨帶：

主要用於螺紋密封、法蘭、閥杆及泵軸填料密封等場合

石墨環：



主要用於壓縮機、機泵、閥門、化工儀器及儀表的熱水、高溫、高壓蒸氣、熱交換液、氨氣、氫氣、有機溶劑、碳氫化合物、低溫液等場合

物理性質：

密度	0.8-1.3 g/cm ³
含碳量	98%-99%
含灰量	1%-2%
含硫量	<1000ppm
含氯量	<50ppm
抗拉強度	45 kg/cm ²
壓縮率	40%
恢復率	>10%
PH 值	0-14

可依客戶需求提供相關尺寸以最短時間交貨

石墨系列

型號		UNI 500®	UNIMETAL®	FGS3	FGS4
顏色					
組成		純石墨板	石墨夾金屬網	SS316L (0.1mm) 沖刺增強 石墨複合板	SS316L (0.05mm) 平板增強 石墨複合板
密度 (g/cm ³) DIN 28090-2		0.9~1.1	0.9~1.1	1.2~1.5	1.15~1.45
最低 / 最高作業溫度 (°C)		- 200 / + 450	- 200 / + 450	- 200 / + 550	- 200 / + 550
最高作業工作壓力 (Bar)		100	150	200	150
洩漏率 (mg*s-1*m-1) DIN 3535-6		≤ 0.1	≤ 0.1	≤ 0.1	≤ 0.1
潛變鬆弛 (%) DIN 3535-6		≤ 8	≤ 8	≤ 5	≤ 5
壓縮率 (%) DIN 3535-6		40~50	40~50	30~45	30~45
復原率 (%) DIN 3535-6		3~7	3~7	3~7	3~7
尺寸規格	長度 * 寬度 (mm)	1500*1500 1500*3000	1500*1500 1500*1000	1500*1500 1500*3000	1500*1500 1500*3000
	厚度 (mm)	0.5~3.0		0.5~3.0	0.5~3.0
公差	長度 * 寬度 (mm)	+/- 50	+/- 50	+/- 50	+/- 50
	厚度 (%)	+/- 10	+/- 10	+/- 10	+/- 10

石墨系列

UNIGRAPH 500

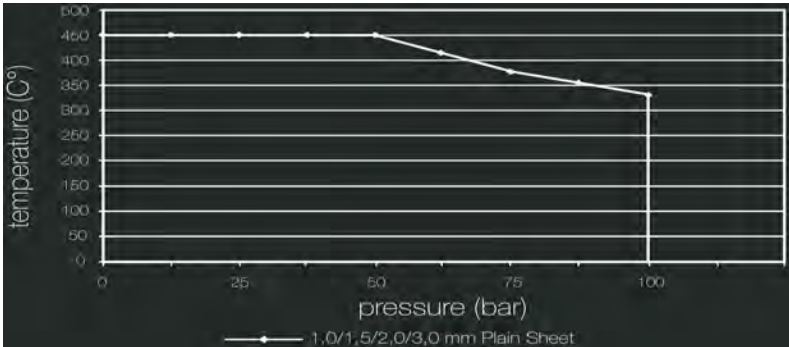

德國勞氏船籍協會



德國家庭用水認證

UNIMETAL

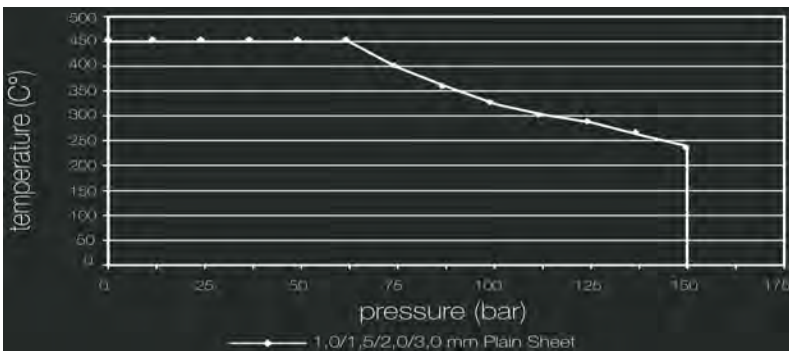

德國勞氏船籍協會

FGS 3

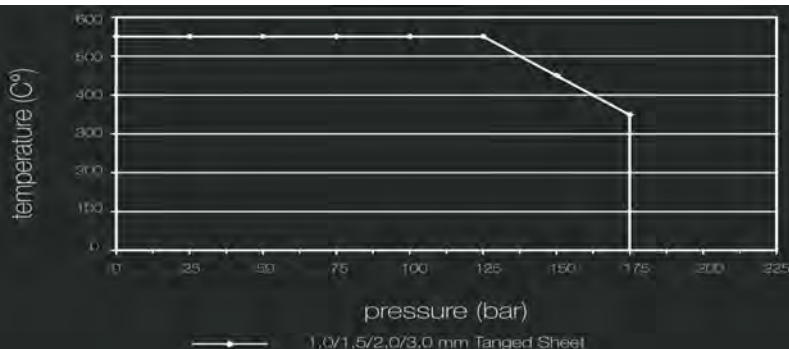

德國勞氏船籍協會



德國氧氣認證



德國煤氣和水行業協會認證



防火 API 6FB 認證



德國檢驗微量洩漏 & 排放

FGS 4

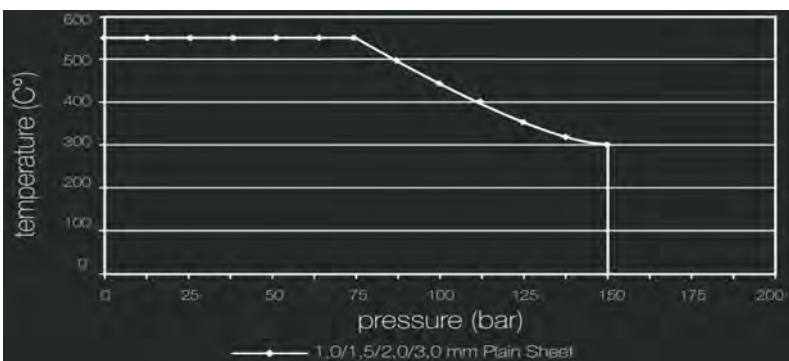

德國氧氣認證



德國煤氣和水行業協會認證



德國檢驗微量洩漏 & 排放

英文名稱	中文名稱	UNI500	FGS3	FGS4	英文名稱	中文名稱	UNI500	FGS3	FGS4
Coke Oven Gas	焦爐煤氣	●	●	●	Fluorine Dioxide	氟氧化鈦	●	●	●
Copper Chloride	氯化銅	●	●	●	Formaldehyde	甲醛	●	●	●
Copper Sulfate	硫酸銅	●	●	●	Formic Acid	蟻酸	●	●	●
Corn Oil	玉米油	●	●	●	Fuel Oil	燃料油	●	●	●
Cotton Seed Oil 10	棉花籽油10	●	●	●	Fuel Oil, Acid	燃料油·酸性	●	●	●
Creosote	雜酚油	●	●	●	Gasoline, Refined	汽油·精製	●	●	●
Cresols, Cresylic Acid	甲酚·甲苯基酸	●	●	●	Gelatin	明膠	●	●	●
Crotonic Acid	巴豆酸	●	●	●	Glucose	葡萄糖	●	●	●
Crude Oil	原油	●	●	●	Glycerine, Glycerol	甘油·甘油	●	●	●
Cumene	異丙苯	●	●	●	Glycol	乙二醇	●	●	●
Cyclohexane	環己	●	●	●	Grain Alcohol	糧食酒	●	●	●
Cyclohexanol	環己醇	●	●	●	Grease, Petroleum Base	潤滑脂·石油基	●	●	●
Cyclohexanone	環己酮	●	●	●	Green Sulfate Liquor	綠酒硫酸	●	●	●
Diazomethane	重氮甲烷	●	●	●	Heptachlor	七氯	●	●	●
Dibenzofuran	二苯並呋喃	●	●	●	Heptane	庚烷	●	●	●
Dibenzylether	二苄	●	●	●	Hexachlorobenzene	六氯苯	●	●	●
Dibromo chloropropane	二溴氯丙烷	●	●	●	Hexachlorobutadiene	六氯丁二烯	●	●	●
Dibromoethane	二溴乙烷	●	●	●	Hexachlorocyclopentadiene	六氯環戊二烯	●	●	●
Dibutyl Phthalate	鄰苯二甲酸二丁酯	●	●	●	Hexachloroethane	六氯乙烷	●	●	●
Dibutyl Sebacate	癸二酸二丁酯	●	●	●	Hexadecane	十六烷	●	●	●
Dichlorobenzene	二氯苯	●	●	●	Hexamethylene Diisocyanate	二異氰酸酯	●	●	●
Dichlorobenzidene	二氯聯苯胺	●	●	●	Hexamethylphosphoramide	六甲基	●	●	●
Dichloroethane	二氯乙烷	●	●	●	Hexane	己烷	●	●	●
Dichloroethylene	二氯乙烯	●	●	●	Hexone	異己酮	●	●	●
Dichloroethyl Ether	二氯乙醚	●	●	●	Hydraulic Oil, Mineral	液壓油·礦物	●	●	●
Dichloromethane	二氯甲烷	●	●	●	Phosphate Esters	磷酸酯	●	●	●
Dichloropropane	二氯丙烷	●	●	●	Hyporazine	聯氨	●	●	●
Dichloropropene	氯丙烯	●	●	●	Hydrobromic Acid	氫溴酸	●	●	●
Dichlorvos	敵敵畏	●	●	●	Hydrochloric Acid	鹽酸	●	●	●
Diesel Oil	柴油	●	●	●	Hydrochloric Acid, dry	鹽酸·乾	●	●	●
Diethanolamine	二乙醇胺	●	●	●	Hydrochloric Acid 20%	鹽酸20%	●	●	●
Diethylaniline	二乙基苯胺	●	●	●	Hydrocyanic Acid	氫氰酸	●	●	●
Diethyl Carbonate	碳酸二乙酯	●	●	●	Hydrofluoric Acid, Anhydrous	氫氟酸·無水	●	●	●
Diethyl Sulfate	硫酸二乙酯	●	●	●	Hydrofluoric Acid, Less than 65%, Above 70°C	氫氟酸·小於65%·大於70°C	●	●	●
Dimethoxybenzidene	二甲氧基	●	●	●	Hydrofluoric Acid, 65% to Anhydrous, Above 70°C	氫氟酸·無水65%·大於70°C	●	●	●
Dimethylaminoazobenzene	二甲胺基	●	●	●	Hydrofluoric Acid, Up to Anhydrous, 70°C & below	氫氟酸·至無水·大於70°C	●	●	●
Dimethyl Aniline	甲基苯胺	●	●	●	Hydrofluorosilicic Acid	氟矽酸	●	●	●
Dimethylbenzidine	二甲基聯	●	●	●	Hydrofluosilicic Acid	氟矽酸	●	●	●
Dimethyl Carbamoyl Chloride	二甲基氨基甲酰氯	●	●	●	Hydrogen	氫	●	●	●
Dimethyl Ether	二甲醚	●	●	●	Hydrogen Bromide	溴化氫	●	●	●
Dimethylformamide	二甲基甲酰胺	●	●	●	Hydrogen Fluoride	氟化氫	●	●	●
Dimethyl Phthalate	鄰苯二甲酸二甲酯	●	●	●	Hydrogen Peroxide, 1 0%	過氧化氫·10%	●	●	●
Dimethyl Sulfate	硫酸二甲酯	●	●	●	Hydrogen Peroxide, 1 0-90%	過氧化氫·10~90%	●	●	●
Dinitrophenol	二硝基苯酚	●	●	●	Hydrogen Sulfide, Dry or Wet	硫化氫·乾或濕	●	●	●
Dinitrotoluene	二硝基甲苯	●	●	●	Hydroquinone	對苯二酚	●	●	●
Dioxane	二惡烷	●	●	●	Iodine Pentafluoride	五氟化碘	●	●	●
Epichlorohydrin	環氧氯丙烷	●	●	●	Iodomethane	碘甲烷	●	●	●
E85 (85% Ethanol, 15% Gas)	E85 (85%乙醇·15%氣體)	●	●	●	Isobutane	異丁烷	●	●	●
Epoxybutane	環氧丁烷	●	●	●	Isooctane	異辛烷	●	●	●
Ethane	乙烷	●	●	●	Isophorone	異佛爾酮	●	●	●
Ethers	醚	●	●	●	Isopropyl Alcohol	異丙Alcohol	●	●	●
Ethyl Acetate	醋酸乙酯	●	●	●	Jet Fuels	噴氣燃料	●	●	●
Ethyl Acrylate	丙烯酸乙酯	●	●	●	Kerosene	煤油	●	●	●
Ethyl Alcohol	乙醇	●	●	●	Lacquer Solvents	漆溶劑	●	●	●
Ethylbenzene	乙苯	●	●	●	Lacquers	漆	●	●	●
Ethyl Carbamate	氨基甲酸乙酯	●	●	●	Lactic Acid, 70°C and below	乳酸·小於等於70°C	●	●	●
Ethyl Cellulose	乙基纖維素	●	●	●	Lactic Acid, Above 70°C	乳酸·大於70°C	●	●	●
Ethyl Chloride	氯乙烷	●	●	●	Lime Salt peter (Calcium Nitrates)	石灰硝石(硝酸鈣)	●	●	●
Ethyl Ether	乙醚	●	●	●	Lindane	林丹	●	●	●
Ethyl Hexoate	乙基己酸	●	●	●	Linseed Oil	亞麻籽油	●	●	●
Ethylene	乙烯	●	●	●	Liquified Petroleum Gas	液化石油氣	●	●	●
Ethylene Bromide	溴乙烯	●	●	●	Lithium Bromide	溴化鋰	●	●	●
Ethylene Dibromide	二溴乙烷	●	●	●	Lithium, Elemental	鋰·元素	●	●	●
Ethylene Dichloride	二氯乙烷	●	●	●	Lubricating Oils, Refined	潤滑油·精	●	●	●
Ethylene Glycol	乙二醇	●	●	●	Lubricating Mineral or Petroleum Types	潤滑礦產或石油類型	●	●	●
Ethyleneimine	乙烯亞胺	●	●	●	Sour	酸	●	●	●
Ethylene Oxide	環氧乙烷	●	●	●	Lye	鹼液	●	●	●
Ethylene Thiourea	乙撐硫脲	●	●	●	Magnesium Chloride	氯化鎂	●	●	●
Ethylidene Chloride	次乙基氯化物	●	●	●	Magnesium Hydroxide	氫氧化鎂	●	●	●
Ferric Chloride	三氯化鐵	●	●	●	Magnesium Sulfate	硫酸鎂	●	●	●
Ferric Phosphate	磷酸鐵	●	●	●	Maleic Acid	馬來酸	●	●	●
Ferric Sulfate	硫酸鐵	●	●	●	Maleic Anhydride	順酐	●	●	●
Fluorine, Gas	氟·氣態	●	●	●	Mercuric Chloride	氯化汞	●	●	●
Fluorine, Liquid	氟·液態	●	●	●	Mercury	汞	●	●	●

英文名稱	中文名稱	UNI500	FGS3	FGS4	英文名稱	中文名稱	UNI500	FGS3	FGS4
Methane	甲烷	●	●	●	Phenol	苯酚	●	●	●
Methanol, Methyl Alcohol	甲醇·甲基醇	●	●	●	Phenylenediamine	苯二胺	●	●	●
Methoxychlor	甲氧	●	●	●	Phosgene	光氣	●	●	●
Methylacrylic Acid	甲基丙烯酸	●	●	●	Phosphate Esters	磷酸酯	●	●	●
Methyl Alcohol	甲醇	●	●	●	Phosphine	膦	●	●	●
Methylaziridine	甲基氮丙啶	●	●	●	Phosphoric Acid, Crude	磷酸·原油	●	●	●
Methyl Bromide	甲基溴	●	●	●	Phosphoric Acid, Pure, Less than 45%	磷酸·純, 小於45%	●	●	●
Methyl Chloride	氯甲烷	●	●	●	Phosphoric Acid, Pure, Above 45%	磷酸·純, 大於45%	●	●	●
Methyl Chloroform	甲基氯仿	●	●	●	Phosphoric Acid, Pure Above 45%, Above 70°C	磷酸·大於45%, 大於70°C	●	●	●
4,4-Methylene-Bis(2-chloroaniline)	4,4-亞甲基-雙(2-氯苯胺)	●	●	●	Phosphorus, Elemental	磷·元素	●	●	●
Methylene Chloride	二氯甲烷	●	●	●	Phosphorus Pentachloride	五氯化磷	●	●	●
Methylene Dianiline	亞甲基二苯胺	●	●	●	Phthalic Acid	鄰苯二甲酸	●	●	●
Methylene Diphenyldiisocyanate	亞甲基二苯基	●	●	●	Phthalic Anhydride	苯酐	●	●	●
Methyl Ethyl Ketone (MEK)	甲基乙基酮	●	●	●	Picric Acid, Molten	苦味酸·熔融	●	●	●
Methyl Hydrazine	甲基肼	●	●	●	Picric Acid, Water Solution	苦味酸·耐水解	●	●	●
Methyl Iodide	碘甲烷	●	●	●	Pinene	蒎烯	●	●	●
Methyl Isobutyl Ketone (MIBK)	甲基異丁基酮	●	●	●	Piperidine	哌啶	●	●	●
Methyl Isocyanate	異氰酸甲酯	●	●	●	Polyacrylonitrile	聚丙烯腈	●	●	●
Methyl Methacrylate	甲基丙烯酸甲酯	●	●	●	Polychlorinated Biphenyls	多氯聯苯	●	●	●
Methyl Pyrrolidone	甲基吡咯烷酮	●	●	●	Potash, Potassium Carbonate	鉀肥·碳酸鉀	●	●	●
Methyl Tert. Butyl Ether (MTBE)	甲基叔丁基醚	●	●	●	Potassium Acetate	醋酸鉀	●	●	●
Milk	牛奶	●	●	●	Potassium Bichromate	重鉻酸鉀	●	●	●
Mineral Oils	礦物油	●	●	●	Potassium Acetate	醋酸鉀	●	●	●
Molten Alkali Metals	熔融鹼金屬	●	●	●	Potassium Bichromate	重鉻酸鉀	●	●	●
Monomethylamine	一甲胺	●	●	●	Potassium Chromate, Red	鉻酸鉀·紅	●	●	●
Muriatic Acid	鹽酸	●	●	●	Potassium Cyanide	氰化鉀	●	●	●
Naphtha	石腦油	●	●	●	Potassium Dichromate	重鉻酸鉀	●	●	●
Naphthalene	萘	●	●	●	Potassium, Elemental	鉀元素	●	●	●
Naphthols	萘酚	●	●	●	Potassium Hydroxide	氫氧化鉀	●	●	●
Natural Gas	天然氣	●	●	●	Potassium Iodide	碘化鉀	●	●	●
Nickel Chloride	氯化鎳	●	●	●	Potassium Nitrate	硝酸鉀	●	●	●
Nickel Sulfate	硫酸鎳	●	●	●	Potassium Permanganate	高錳酸鉀	●	●	●
Nitric Acid, Less than 30%	硝酸·小於30%	●	●	●	Potassium Sulfate	硫酸鉀	●	●	●
Nitric Acid, Above 30%	硝酸·大於30%	●	●	●	Producer Gas	作業中煤氣	●	●	●
Nitric Acid, Crude	粗硝酸	●	●	●	Propane	丙烷	●	●	●
Nitric Acid, Red Fuming	發煙硝酸	●	●	●	Propane Sultone	丙烷磺內酯	●	●	●
Nitrobenzene	硝基苯	●	●	●	Beta-Propiolactone	β-丙內酯	●	●	●
Nitrobiphenyl	硝基	●	●	●	Propionaldehyde	丙醛	●	●	●
Nitro-Butanol	硝基丁醇	●	●	●	Propyl Alcohol	丙醇	●	●	●
Nitrocalcite (Calcium Nitrate)	硝酸鈣	●	●	●	Propyl Nitrate	硝酸丙酯	●	●	●
Nitrogen	氮	●	●	●	Propylene	丙烯	●	●	●
Nitrogen Tetroxide	四氧化二氮	●	●	●	Propylene Dichloride	二氯丙烯	●	●	●
Nitrohydrochloric Acid (Aqua Regia)	硝酸鹽酸(王水)	●	●	●	Propylene Glycol	丙二醇	●	●	●
Nitromethane	硝基甲烷	●	●	●	Propylene Oxide	環氧丙烷	●	●	●
2-Nitro-2-Methyl Propanol	2-硝基-2-甲基丙醇	●	●	●	Propylenimine	丙烯亞胺	●	●	●
Nitromuriatic Acid (Aqua Regia)	硝酸(王水)	●	●	●	Prussic Acid, Hydrocyanic Acid	氫氰酸·氫氰酸	●	●	●
Nitrophenol	硝基苯酚	●	●	●	Pyridine	吡啶	●	●	●
Nitropropane	硝基	●	●	●	Quinoline	喹啉	●	●	●
Nitrosodimethylamine	亞硝胺	●	●	●	Quinone	醌	●	●	●
Nitroso Methylurea	氮甲基脲	●	●	●	Refrigerant type 10	製冷劑型號 10	●	●	●
Nitrosomorpholine	亞硝基	●	●	●	Refrigerant type 11	製冷劑型號 11	●	●	●
Norge Niter (Calcium Nitrate)	硝酸鎳(硝酸鈣)	●	●	●	Refrigerant type 12	製冷劑型號 12	●	●	●
Norwegian Saltpeter (Calcium Nitrate)	挪威硝(硝酸鈣)	●	●	●	Refrigerant type 13	製冷劑型號 13	●	●	●
Octadecyl Alcohol	十八烷醇	●	●	●	Refrigerant type 13B1	製冷劑型號 13B1	●	●	●
Octane	辛烷值	●	●	●	Refrigerant type 21	製冷劑型號 21	●	●	●
Oil, Petroleum	石油·工業油	●	●	●	Refrigerant type 22	製冷劑型號 22	●	●	●
Oils, Animal and Vegetable	動物油·植物油	●	●	●	Refrigerant type 23	製冷劑型號 23	●	●	●
Oleic Acid	油酸	●	●	●	Refrigerant type 31	製冷劑型號 31	●	●	●
Oleum	發煙硫酸	●	●	●	Refrigerant type 32	製冷劑型號 32	●	●	●
Orthodichlorobenzene	鄰二氯苯	●	●	●	Refrigerant type 112	製冷劑型號 112	●	●	●
Oxalic Acid	草酸	●	●	●	Refrigerant type 113	製冷劑型號 113	●	●	●
Oxygen, Gas (BAM Approval)	氧氣·煤氣(BAM批准)	●	●	●	Refrigerant type 114	製冷劑型號 114	●	●	●
Ozone	臭氧	●	●	●	Refrigerant type 114B2	製冷劑型號 114B2	●	●	●
Palmitic Acid	棕櫚酸	●	●	●	Refrigerant type 115	製冷劑型號 115	●	●	●
Paraffin	石蠟	●	●	●	Refrigerant type 123	製冷劑型號 123	●	●	●
Parathion	對硫磷	●	●	●	Refrigerant type 124	製冷劑型號 124	●	●	●
Paraxylene	對二甲苯	●	●	●	Refrigerant type 125	製冷劑型號 125	●	●	●
Pentachloronitrobenzene	五氯硝基苯	●	●	●	Refrigerant type 134a	製冷劑型號 134a	●	●	●
Pentachlorophenol	五氯酚	●	●	●	Refrigerant type 141b	製冷劑型號 141B	●	●	●
Pentane	戊烷	●	●	●	Refrigerant type 142b	製冷劑型號 142B	●	●	●
Perchloric Acid	高氯酸	●	●	●	Refrigerant type 143a	製冷劑型號 143A	●	●	●
Perchloroethylene	四氯乙烯	●	●	●	Refrigerant type 152a	製冷劑型號 152A	●	●	●
Petroleum Oils, Crude	石油·原油	●	●	●	Refrigerant type 218	製冷劑型號 218	●	●	●
Petroleum Oils, Refined	石油·精製	●	●	●	Refrigerant type 290 (Propane)	製冷劑型號 290(丙烷)	●	●	●





金屬 / 半金屬系列

金屬渦卷墊片

Spiral Wound Gasket

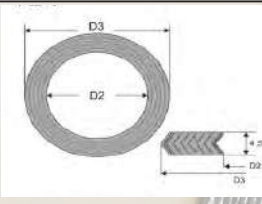
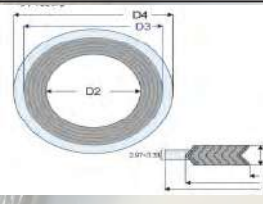
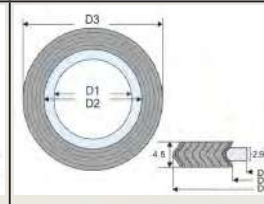
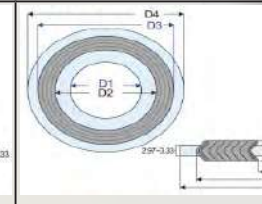
由螺旋纏繞的 V 形不銹鋼帶和非金屬填充材料，如石墨或聚四氟乙烯組成。墊片上還有一個實心外圈，用於定心和控制壓縮。螺旋纏繞墊片是工業工廠中最常用的金屬墊片。正確選擇和安裝的纏繞墊片可以承受高溫、高壓、腐蝕性液體、易燃液體、氫氣等在其預期使用壽命期間防止洩漏。

型式有效範圍

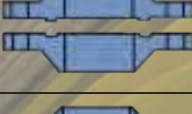
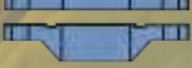
名稱	本體式	外環式	內環式	內外環式
剖面				
石墨	OL#6590	OL#6591	OL#6592	OL#6596
膨體四氟	OL#7590	OL#7591	OL#7592	OL#7596
非石棉	OL#8590	OL#8591	OL#8592	OL#8596
複合材料	OL#9590	OL#9591	OL#9592	OL#9596
	不適用	適用 1/2"~60"	不適用	適用 1/2"~60"
	不適用	適用 1/2"~60"	不適用	適用 1/2"~60"
	適用 1/2"~24"	不適用	適用 1/2"~24"	不適用
	適用 1/2"~24"	不適用	不適用	不適用
	適用 1/2"~24"	不適用	不適用	不適用

金屬 / 半金屬系列 金屬渦卷墊片

型號對照表

O # 6 5 9 0 - E E E

非金屬填 料帶材質	型式	內 / 外 環材質	纏繞金屬帶材質
6- 石墨	0- 基本式	S-Low Carbon Steel Y-Inconel 600.625	E-304SS Y-Inconel 600.625
7- 膨體四氟	1- 外環式	E-304SS Y1-Inconel X750	L-304LSS Y1-Inconel X750
8- 非石棉	2- 內環式	L-304LSS W-Inconel 800/825	G-316SS W-Inconel 800/825
9- 雲母、 陶瓷纖維	6- 內外環式	G-316SS T-Titanium	H-316LSS T-Titanium
		H-316LSS X1-Hastelloy	O-310SS X1-Hastelloy B2.B3
		O-310SS B2.B3	P-316Ti SS X2-Hastelloy C276
		P-316Ti SS X3-Hastelloy C22	Q-317LSS X3-Hastelloy C22
		Q-317LSS A-Aluminum	J-321SS A-Aluminum
		J-321SS C-Copper	K-347SS C-Copper
		K-347SS B-Bronze	R-410SS B-Bronze
		R-410SS Z-Zirconium 702	U-430SS Z-Zirconium 702
		U-430SS I1-Duplex S31803/S32205	F-904LSS I1-Duplex S31803/S32205
		F-904LSS I2-Alloy 20	M-Monel 400 I2-Alloy 20
		M-Monel 400 I3-Super Duplex	N-Nickel 200 I3-Super Duplex S32750
		N-Nickel 200 S32750	

有效範圍

填料	石墨 (Graphite)	膨體四氟	非石棉	雲母 / 石墨
溫度範圍 (°C)	-200 ~ 450 (一般) -200 ~ 650 (低氧)	-200 ~ 250	-150 ~ 250	-100 ~ 800
最大壓力 (bar)	300	200	300	100

複合材料填料

結合雲母的超高溫穩定性與石墨的優異回彈密封性能，內外層雲母可有效承受高溫環境並維持結構穩定，中層石墨提供主要密封與回彈效果，適用於高溫蒸氣、熱循環及嚴苛工況，可有效提升渦捲式墊片的耐溫能力、密封可靠度與使用壽命。

標準型

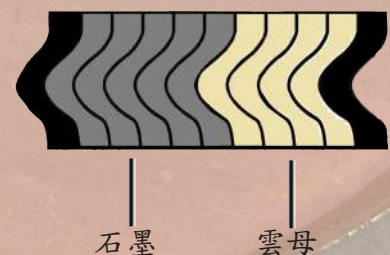
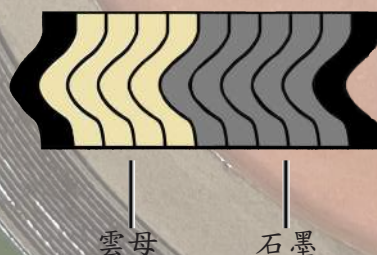
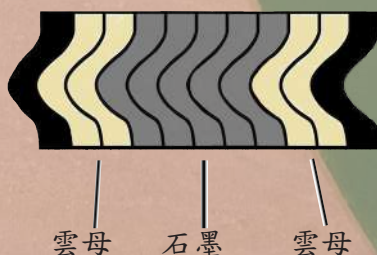

可依客戶特殊需求配置組合製作

渦卷型密封墊料尺寸表

根據ASME B16.20 適用於ANSI B16.5法蘭

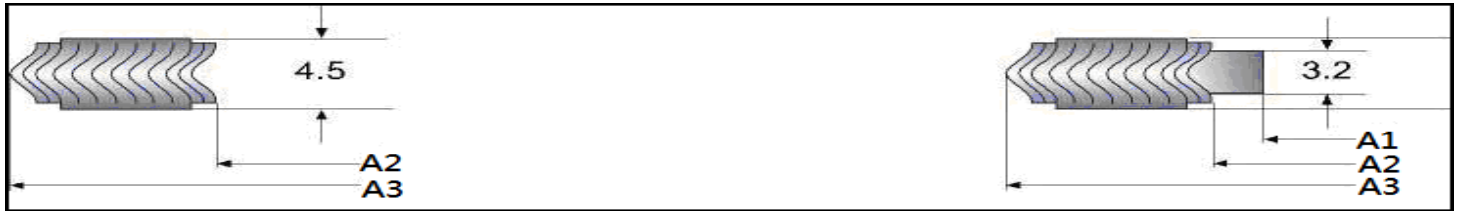

單位:mm

法蘭尺寸	內環 / 內徑	Large Male and Female		Large Tongue and Groove		Small Tongue and Groove	
	150-1500#	150-1500#		150-2500#		150-2500#	
	A1	內徑A2	外徑A3	內徑A2	外徑A3	內徑A2	外徑A3
1/2"	14.3	25.4	34.9	25.4	34.9	25.4	34.9
3/4"	20.6	33.3	42.9	33.3	42.9	33.3	42.9
1"	27	38.1	50.8	38.1	50.8	38.1	47.6
1-1/4"	34.9	47.6	63.5	47.6	63.5	47.6	57.2
1-1/2"	41.3	54	73	54	73	54	63.5
2"	52.4	73	92.1	73	92.1	73	82.6
2-1/2"	63.5	85.7	104.8	85.7	104.8	85.7	95.3
3"	77.8	108	127	107.8	127	108	117.5
3-1/2"	90.5	120.7	139.7	120.7	139.7	120.7	130.2
4"	103.2	131.8	157.2	131.8	157.2	131.8	144.5
5"	128.6	160.3	185.7	160.3	185.7	160.3	173
6"	154	190.5	215.9	190.5	215.9	190.5	203.2
8"	203.2	238.1	269.9	238.1	269.9	238.1	254
10"	254	285.8	323.9	285.8	323.9	285.8	304.8
12"	303.2	342.9	381	342.9	381	342.9	362
14"	342.9	374.7	412.8	374.7	412.8	374.7	393.7
16"	393.7	425.5	469.9	425.5	469.9	425.5	447.7
18"	444.5	489	533.4	489	533.4	489	511.2
20"	495.3	533.4	584.2	533.4	584.2	533.4	558.2
24"	596.9	641.4	692.2	641.4	692.2	641.4	666.8

渦卷型密封墊料尺寸表

根據ASME B16.20 適用於ANSI B16.5法蘭



*400#法蘭無1/2"~3", 須參考600#.

單位:mm

法蘭尺寸	150#				300#				400#			
	A1	A2	A3	A4	A1	A2	A3	A4	A1	A2	A3	A4
1/2"	14.2	19.1	31.8	47.8	14.2	19.1	31.8	54.1	-	-	-	-
3/4"	20.6	25.4	39.6	57.2	20.6	25.4	39.6	66.8	-	-	-	-
1"	26.9	31.8	47.8	66.8	26.9	31.8	47.8	73.2	-	-	-	-
1-1/4"	38.1	47.8	60.5	76.2	38.1	47.8	60.5	82.6	-	-	-	-
1-1/2"	44.5	54.1	69.9	85.9	44.5	54.1	69.9	95.3	-	-	-	-
2"	55.6	69.9	85.9	104.9	55.6	69.9	85.9	111.3	-	-	-	-
2-1/2"	66.5	82.6	98.6	124	66.5	82.6	98.6	130.3	-	-	-	-
3"	81	101.6	120.7	136.7	81	101.6	120.7	149.4	-	-	-	-
4"	106.4	127	149.4	174.8	106.4	127	149.4	181.1	102.6	120.7	149.4	177.8
5"	131.8	155.7	177.8	196.9	131.8	155.7	177.8	215.9	128.3	147.6	177.8	212.9
6"	157.2	182.6	209.6	222.3	157.2	182.6	209.6	251	154.9	174.8	209.6	247.7
8"	215.9	233.4	263.7	279.4	215.9	233.4	263.7	308.1	205.7	225.6	263.7	304.8
10"	268.2	287.3	317.5	339.9	268.2	287.3	317.5	362	255.3	274.6	317.5	358.9
12"	317.5	339.9	374.7	409.7	317.5	339.9	374.7	422.4	307.3	327.2	374.7	419.1
14"	349.3	371.6	406.4	450.9	349.3	371.6	406.4	485.9	342.9	362	406.4	482.6
16"	400.1	422.4	463.6	514.4	400.1	422.4	463.6	539.8	389.9	412.8	463.6	536.7
18"	449.3	474.7	527.1	549.4	449.3	474.7	527.1	596.9	438.2	469.9	527.1	593.9
20"	500.1	525.5	577.9	606.6	500.1	525.5	577.9	654.1	489	520.7	577.9	647.7
24"	603.3	628.7	685.8	717.6	603.3	628.7	685.8	774.7	590.6	628.7	685.8	768.4

渦卷型密合墊料尺寸表

根據ASME B16.20

適用於ANSI B16.5法蘭



*900#法蘭無1/2"~2-1/2", 需參考1500#.

*2500#法蘭無14" 或以上的尺寸

單位: mm

法蘭尺寸	600#				900#				1500#				2500#			
	A1	A2	A3	A4	A1	A2	A3	A4	A1	A2	A3	A4	A1	A2	A3	A4
1/2"	14.2	19.1	31.8	54.1	-	-	-	-	14.2	19.1	31.8	63.5	14.2	19.1	31.8	69.9
3/4"	20.6	25.4	39.6	66.8	-	-	-	-	20.6	25.4	39.6	69.9	20.6	25.4	39.6	76.2
1"	26.9	31.8	47.8	73.2	-	-	-	-	26.9	31.8	47.8	79.5	26.9	31.8	47.8	85.9
1-1/4"	38.1	47.8	60.5	82.6	-	-	-	-	33.3	39.6	60.5	88.9	33.3	39.6	60.5	104.9
1-1/2"	44.5	54.1	69.9	95.3	-	-	-	-	41.4	47.8	69.9	98.6	41.4	47.8	69.9	117.6
2"	55.6	69.9	85.9	111.3	-	-	-	-	52.3	58.7	85.9	143	52.3	58.7	85.9	146.1
2-1/2"	66.5	82.6	98.6	130.3	-	-	-	-	63.5	69.9	98.6	165.1	63.5	69.9	98.6	168.4
3"	78.7	101.6	120.7	149.4	78.7	95.25	120.7	168.4	78.7	92.2	120.7	174.8	78.7	92.2	120.7	196.9
4"	102.6	120.7	149.4	193.8	102.6	120.7	149.4	206.5	97.8	117.6	149.4	209.6	97.8	117.6	149.4	235
5"	128.3	147.6	177.8	241.3	128.3	147.6	177.8	247.7	124.5	143	177.8	254	124.5	143	177.8	279.4
6"	154.9	174.8	209.6	266.7	154.9	174.8	209.6	289.1	147.3	171.5	209.6	282.7	147.3	171.5	209.6	317.5
8"	205.7	225.6	263.7	320.8	205.7	222.3	257.3	358.9	196.9	215.9	257.3	352.6	196.9	215.9	257.3	387.4
10"	255.3	274.6	317.5	400.1	255.3	276.4	311.2	435.1	246.1	266.7	311.2	435.1	246.1	270	311.2	476.3
12"	307.3	327.2	374.7	457.2	307.3	323.9	368.3	498.6	292.1	323.9	368.3	520.7	292.1	317.5	368.3	549.4
14"	342.9	362	406.4	492.3	342.9	355.6	400.1	520.7	320.8	362	400.1	577.9	-	-	-	-
16"	389.9	412.8	463.6	565.2	389.9	412.8	457.2	574.8	368.3	406.4	457.2	641.4	-	-	-	-
18"	438.2	469.9	527.1	612.9	438.2	463.6	520.7	638.3	425.5	463.6	520.7	704.9	-	-	-	-
20"	489	520.7	577.9	682.8	489	520.7	571.5	698.5	476.3	514.4	571.5	755.7	-	-	-	-
24"	590.6	628.7	685.8	790.7	590.6	628.7	679.5	838.2	577.9	616	679.5	901.7	-	-	-	-

渦卷型密合墊料尺寸表

根據ASME B16.20 適用於ANSI B16.47系列A(MSS-SP44)法蘭



*900#法蘭無50" 或以上的尺寸

單位:mm

法蘭尺寸	150#				300#				400#				600#				900#			
	A1	A2	A3	A4	A1	A2	A3	A4	A1	A2	A3	A4	A1	A2	A3	A4	A1	A2	A3	A4
26"	654.1	673.1	704.9	774.7	654.1	685.8	736.6	835.2	660.4	685.8	736.6	831.9	647.7	685.8	736.6	866.9	660.4	685.8	736.6	882.7
28"	704.9	723.9	755.7	831.9	704.9	736.6	787.4	898.7	711.2	736.6	787.4	892.3	698.5	736.6	787.4	914.4	711.2	736.6	787.4	946.2
30"	755.7	774.7	806.5	882.7	755.7	793.8	844.6	952.5	755.7	793.8	844.6	946.2	755.7	793.8	844.6	971.6	768A	793.8	844.6	1009.7
32"	806.5	825.5	860.6	939.8	806.5	850.9	901.7	1006.6	812.8	850.9	901.7	1003.3	812.8	850.9	901.7	1022.4	812.8	850.9	901.7	1073.2
34"	857.3	876.3	911.4	990.6	857.3	901.7	952.5	1057.4	863.6	901.7	952.5	1054.1	863.6	901.7	952.5	1073.2	863.6	901.7	952.5	1136.7
36"	908.1	927.1	968.5	1047.8	908.1	955.8	1006.6	1117.6	917.7	955.8	1006.6	1117.6	917.7	955.8	1006.6	1130.3	920.8	958.9	1009.7	1200.2
38"	958.9	977.9	1019.3	1111.3	952.5	977.9	1016	1054.1	952.5	971.6	1022.4	1073.2	952.5	990.6	1041.4	1104.9	1009.7	1035.1	1085.9	1200.2
40"	1009.7	1028.7	1070.1	1162.1	1003.3	1022.4	1070.1	1114.6	1000.3	1025.7	1076.5	1127.3	1009.7	1047.8	1098.6	1155.7	1060.5	1098.6	1149.4	1251.0
42"	1060.5	1079.5	1124.0	1219.2	1054.1	1073.2	1120.9	1165.4	1051.1	1076.5	1127.3	1178.1	1066.8	1104.9	1155.7	1219.2	1111.3	1149.4	1200.2	1301.8
44"	1111.3	1130.3	1178.1	1276.4	1104.9	1130.3	1181.1	1219.2	1104.9	1130.3	1181.1	1231.9	1111.3	1162.1	1212.9	1270.0	1155.7	1206.5	1257.3	1368.6
46"	1162.1	1181.1	1228.9	1327.2	1152.7	1178.1	1228.9	1273.3	1168.4	1193.8	1244.6	1289.1	1162.1	1212.9	1263.7	1327.2	1219.2	1270.0	1320.8	1435.1
48"	1212.9	1231.9	1279.7	1384.3	1209.8	1235.2	1286.0	1324.1	1206.5	1244.6	1295.4	1346.2	1219.2	1270.0	1320.8	1390.7	1270.0	1320.8	1371.6	1485.9
50"	1263.7	1282.7	1333.5	1435.1	1244.6	1295.4	1346.2	1378.0	1257.3	1295.4	1346.2	1403.4	1270.0	1320.8	1371.6	1447.8	-	-	-	-
52"	1314.5	1333.5	1384.3	1492.3	1320.8	1346.2	1397.0	1428.8	1308.1	1346.2	1397.0	1454.2	1320.8	1371.6	1422.4	1498.6	-	-	-	-
54"	1358.9	1384.3	1435.1	1549.4	1352.6	1403.4	1454.2	1492.3	1352.6	1403.4	1454.2	1517.7	1378.0	1428.8	1479.6	1555.8	-	-	-	-
56"	1409.7	1435.1	1485.9	1606.6	1403.4	1454.2	1505.0	1543.1	1403.4	1454.2	1505.0	1568.5	1428.8	1479.6	1530.4	1612.9	-	-	-	-
58"	1460.5	1485.9	1536.7	1663.7	1447.8	1511.3	1562.1	1593.9	1454.2	1505.0	1555.8	1619.3	1473.2	1536.7	1587.5	1663.7	-	-	-	-
60"	1511.3	1536.7	1587.5	1714.5	1524.0	1562.1	1612.9	1644.7	1517.7	1568.5	1619.3	1682.8	1530.4	1593.9	1644.7	1733.6	-	-	-	-

渦卷型密封墊料尺寸表

根據ASME B16.20 適用於ANSI B16.47系列B(API 605)法蘭



*900#法蘭無50"或以上的尺寸

單位:mm

法蘭尺寸	150#				300#				400#				600#				900#			
	A1	A2	A3	A4	A1	A2	A3	A4	A1	A2	A3	A4	A1	A2	A3	A4	A1	A2	A3	A4
26"	654.1	673.1	698.5	725.4	654.1	673.1	711.2	771.7	654.1	666.8	698.5	746.3	644.7	663.7	714.5	765.3	666.8	692.2	749.3	838.2
28"	704.9	723.9	749.3	776.2	704.9	723.9	762	825.5	701.8	714.5	749.3	800.1	685.8	704.9	755.7	819.2	717.6	743	800.1	901.7
30"	755.7	774.7	800.1	827	755.7	774.7	812.8	886	752.6	765.3	806.5	857.3	752.6	778	828.8	879.6	781.1	806.5	857.3	958.9
32"	806.5	825.5	850.9	881.1	806.5	825.5	863.6	939.8	800.1	812.8	860.6	911.4	793.8	831.9	882.7	933.5	838.2	863.6	914.4	1016
34"	857.3	876.3	908.1	935	857.3	876.3	914.4	993.9	850.9	866.9	911.4	962.2	850.9	889	939.8	997	895.4	920.8	971.6	1073.2
36"	908.1	927.1	958.9	987.6	908.1	927.1	965.2	1047.8	898.7	917.7	965.2	1022.4	901.7	939.8	990.6	1047.8	920.8	946.2	997	1124
38"	958.9	974.6	1009.7	1044.7	971.6	1009.7	1047.8	1098.6	952.5	971.6	1022.4	1073.2	952.5	990.6	1041.4	1104.9	1009.7	1035.1	1085.9	1200.2
40"	1009.7	1022.4	1063.8	1095.5	1022.4	1060.5	1098.6	1149.4	1000.3	1025.7	1076.5	1127.3	1009.7	1047.8	1098.6	1155.7	1060.5	1098.6	1149.4	1251
42"	1060.5	1079.5	1114.6	1146.3	1085.9	1111.3	1149.4	1200.2	1051.1	1076.5	1127.3	1178.1	1066.8	1104.9	1155.7	1219.2	1111.3	1149.4	1200.2	1301.8
44"	1111.3	1124	1165.4	1197.1	1124	1162.1	1200.2	1251	1104.9	1130.3	1181.1	1231.9	1111.3	1162.1	1212.9	1270	1155.7	1206.5	1257.3	1368.6
46"	1162.1	1181.1	1224	1255.8	1178.1	1216.2	1254.3	1317.8	1168.4	1193.8	1244.6	1289.1	1162.1	1212.9	1263.7	1327.2	1219.2	1270	1320.8	1435.1
48"	1212.9	1231.9	1270	1306.6	1231.9	1263.7	1311.4	1368.6	1206.5	1244.6	1295.4	1346.2	1219.2	1270	1320.8	1390.7	1270	1320.8	1371.6	1485.9
50"	1263.7	1282.7	1325.6	1357.4	1267	1317.8	1355.9	1419.4	1257.3	1295.4	1346.2	1403.4	1270	1320.8	1371.6	1447.8	-	-	-	-
52"	1314.5	1333.5	1376.4	1408.2	1317.8	1368.6	1406.7	1470.2	1308.1	1346.2	1397	1454.2	1320.8	1371.6	1422.4	1498.6	-	-	-	-
54"	1365.3	1364.3	1422.4	1463.8	1365.3	1403.4	1454.2	1530.4	1352.6	1403.4	1454.2	1517.7	1378	1428.8	1479.6	1555.8	-	-	-	-
56"	1422.4	1444.8	1477.8	1514.6	1428.8	1479.6	1524	1593.9	1403.4	1454.2	1505	1568.5	1428.8	1479.6	1530.4	1612.9	-	-	-	-
58"	1478	1500.4	1528.8	1579.6	1484.4	1535.2	1573.3	1655.8	1454.2	1505	1555.8	1619.3	1473.2	1536.7	1587.5	1663.7	-	-	-	-
60"	1535.2	1557.3	1586	1630.4	1557.3	1589	1630.4	1706.6	1517.7	1568.5	1619.3	1682.8	1530.4	1593.9	1644.7	1733.6	-	-	-	-

渦卷型密合墊料尺寸表

DIN 2690, 2691, 2692



單位:mm

法蘭 尺寸	PN10				PN16				PN25				PN40				PN64			
	A1	A2	A3	A4	A1	A2	A3	A4	A1	A2	A3	A4	A1	A2	A3	A4	A1	A2	A3	A4
DN15	24	30	42	51	24	30	42	51	24	30	42	51	24	30	42	51	24	30	42	61
DN20	27	33	47	61	27	33	47	61	27	33	47	61	27	33	47	61	27	33	47	72
DN25	34	40	54	71	34	40	54	71	34	40	54	71	34	40	54	71	34	40	54	82
DN32	44	50	66	82	44	50	66	82	44	50	66	82	44	50	66	82	44	50	66	87
DN40	51	57	73	92	51	57	73	92	51	57	73	92	51	57	73	92	51	57	73	103
DN50	59	69	87	107	59	69	87	107	59	69	87	107	59	69	87	107	59	69	87	113
DN65	73	83	103	127	73	83	103	127	73	83	103	127	73	83	103	127	73	83	105	138
DN80	87	97	117	142	87	97	117	142	87	97	117	142	87	97	117	142	87	97	121	148
DN100	114	124	144	162	114	124	144	162	114	124	144	168	114	124	144	168	114	124	148	174
DN125	140	150	172	192	140	150	172	192	140	150	172	194	140	150	172	194	140	150	176	210
DN150	168	178	200	217	168	178	200	217	168	178	200	224	168	178	200	224	168	178	207	247
DN200	220	230	256	272	220	230	256	272	220	230	256	284	220	230	256	290	220	230	262	309
DN250	269	279	307	327	269	279	307	328	269	279	307	340	269	279	307	352	269	279	315	364
DN300	319	329	357	377	319	329	357	383	319	329	357	400	319	329	357	417	319	329	365	424
DN350	365	375	405	437	365	375	405	443	365	375	405	457	365	375	405	474	365	375	413	486
DN400	416	426	458	488	416	426	458	495	416	426	458	514	416	426	458	546	416	426	466	543
DN500	520	530	566	593	520	530	566	617	520	530	566	624	520	530	566	628	520	530	574	657
DN600	615	630	666	695	615	630	666	734	615	630	666	731	615	630	666	747	615	630	674	764
DN700	715	730	770	810	715	730	770	804	715	730	770	833	715	730	770	852	715	730	778	879
DN800	815	830	874	917	815	830	874	911	815	830	874	942	815	830	874	974	815	830	882	988

金屬 / 半金屬系列

金屬包覆型墊片





Metal Jacketed Gasket

金屬包覆墊片是以金屬薄片完全包覆高耐溫的無機填料或非石棉墊材，可依各種非規格尺寸、材質、型式，多由人工產製，特別適用於密封熱交換器、氣體管道、鑄鐵法蘭和高壓釜等。這些墊圈的彈性和恢復性能是有限的，為了有效密封，金屬護套墊片需要法蘭表面光滑潔、高螺栓載荷和法蘭平面平整，否則密封失敗。

型號對照表

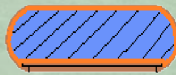
OL# 5200 - 304SS / FG

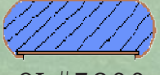
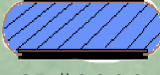
代表 304SS 金屬包覆石墨填料

表面材質	型式	金屬包覆材質		非金屬填料材質
5- 無 6- 石墨	 2- 單層 OL#5200  OL#6200	Low Carbon	Inconel 600 / 625	FG 石墨
		304SS	Incoloy 800(H) / 825	PTFE 四氟
304LSS		Titanium	NA 非石棉	
316SS		Hastelloy B2/B3	CE 陶瓷纖維	
316LSS		Hastelloy C276		
316TiSS		Hastelloy C22		
8- 雙層	 OL#5800  OL#6800	317LSS	Aluminum	
		321SS	Copper	
		347SS	Bronze	
		410SS	Duplex S31803/S32205	
1- 波浪	 OL#5100	5Cr-0.5Mo	Alloy 20	
		Monel 400	Others	
		Nickel 200		

金屬 / 半金屬系列 金屬波紋墊片

Metal Corrugated Gasket

波紋金屬墊片由金屬芯組成，金屬芯兩側帶有同心凹槽，並塗有膨脹石墨、聚四氟乙烯層或無石棉板，既有金屬的強度，又有波形彈性的點，耐高溫、腐蝕和溫度變化，密封性能優異，泛用性佳。

波紋金屬芯具有多道同心圓密封，覆層密封墊材不易吹出蠕變鬆弛，所需螺栓鎖緊力較低，可長期保持密封性能。同時，非金屬覆層受壓後可貼合填入法蘭表面缺陷，形成近似金屬面接合 (MMC)，適用於熱交換器、管道、閥門等法蘭接頭的密封。

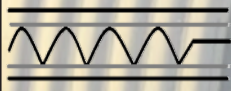
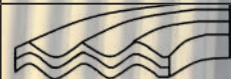
編號	剖面	金屬材質	非金屬材質	溫度範圍	耐壓 (bar)
OL#5000		304SS	柔性石墨	-200~450(一般) -200~650(低氧)	150
OL#5010		316LSS	膨體四氟	膨體四氟 -200~260	

金屬 / 半金屬系列





金屬環接型墊片

Metal Ring Joint Gasket

金屬環墊片是由多種不同金屬材質組成，環型接頭墊片在固定時會被擠入法蘭凹槽中，是適用於高壓、高溫的金屬密封墊圈。主要用於海上和陸上石化工業、油田鑽井和完井設備、閥門和管道組件等，帶有高完整性壓力容器接頭。必須根據與介質的化學相容性和法蘭硬度來選擇正確的墊片材料，確保墊片有足夠的變形而不損壞法蘭面。

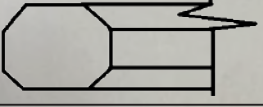
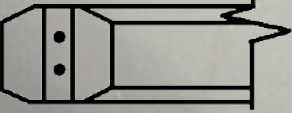
注意：選用的金屬環材質硬度應低於法蘭 15~20 HB，而且舊品不建議重複，因材質可能發生加工硬化而損及法蘭或密封性能。

型式

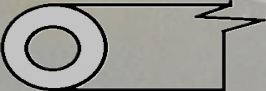
剖面	名稱	編號
	橢圓型 Oval	OL#5500-OV
	八角型 Octagonal	OL#5500-OT
	BX 高壓型	OL#5500-BX
	RX 高壓型	OL#5500-RX
	三角型 Delta	OL#5500-DT
	鐘型 Lens	OL#5500-LN
	中空型 Hollow	OL#5500-HL

金屬 / 半金屬系列

金屬環接型墊片

型號對照表

OL#5500-OV-AG-E

<p>型式</p>	<p>OV- 橢圓型 (Oval) OT- 角型 (Octagonal) BX-BX 高壓型 RX-RX 高壓型 DT- 三角型 (Deita) LN- 鏡型 (Lens) HL- 中空型 Hollow HLI- 中空型 Hollow (內孔) HLX- 中空型 Hollow (外孔)</p>	
<p>表面處理 (鍍膜)</p>	<p>Blank- 無 Nil PF- 四氟 PTFE AG- 銀 Silver MO-MOS2 Z- 其他</p>	
<p>材質</p>	<p>D-Soft Iron S-Low Carbon Steel E-304SS L-304LSS G-316SS H-316LSS O-310SS P-316TISS J-321SS K-347SS R-410SS U-430SS</p>	<p>F-5Cr=0.5Mo M-Monel 400 N-Nickel 200 Y-Inconel 600/625 W-Incoloy 800(H)/825 T-Titanium X1-Hastelloy B2 X2-Hastelloy C276 X3-Hastelloy C22 A-Aluminum C-Copper V-Others</p>

API 6A 建議材質及最高硬度如下表所示，另外亦可選用如鉻鉬鋼 (5Cr=0.5Mo)、Monel、Inconel、Hastelloy、Duplex 雙相鋼等特殊鋼種。

金屬 / 半金屬系列

金屬環接型墊片

材質特性

分類		材質 名稱	材質硬度		使用溫度°C (最高)
			Brinell BHN/HB	Rockwell HRB	
常用 材質	碳鋼	S- Low Carbon Steel	120	68	540
		D- Soft Iron	90	56	500
		F- 5Cr=0.5Mo	130	72	650
	不鏽鋼	E- 304SS	160	83	540
		L-304LSS	160	83	540
		G-316SS	160	83	815
		H-316LSS	160	83	815
		R-410SS	170	86	850
	非含鐵金屬	C-Copper	81	41	315
		A-Aluminum	35	-	425
特殊 材質	合金不鏽鋼	J-321SS	160	83	870
		K-347SS	160	83	870
		Y-Inconel 600/625	150	78	1095
		W-Incoloy 800(H)/825	150	78	1095
	非含鐵金屬	M-Monel 400	160	83	760
		T-Titanium	160	83	540
		N-Nickel 200	120	68	760
		X1-Hastelloy B2/B3	230	98	1095
		X2/X3-Hastelloy C276/C22	210	96	1095

※ 建議金屬環之材質硬度應低於所應用法蘭之材質硬度。

※ 金屬環之材質硬度應低於以上列表所示之硬度數值。

金屬環接型墊片尺寸表

單位: mm

法蘭尺寸/壓力											尺寸						
ASME-ANSI B16.5					ASME B16-47A			API16B			環號	P	A	B	H	C	R1
150	300-600	900	1500	2500	150	300-600	900	2000	3000	5000							
	1/2"										R11	34.14	6.35	11.2	9.7	4.32	1.5
		1/2"	1/2"								R12	39.70	7.95	14.2	12.7	5.23	1.5
	3/4"			1/2"							R13	42.88	7.95	14.2	12.7	5.23	1.5
		3/4"	3/4"								R14	44.45	7.95	14.2	12.7	5.23	1.5
1"											R15	47.63	7.95	14.2	12.7	5.23	1.5
	1"	1"	1"	3/4"				1"	1"	1"	R16	50.80	7.95	14.2	12.7	5.23	1.5
1-1/4"											R17	57.15	7.95	14.2	12.7	5.23	1.5
	1-1/4"	1-1/4"	1-1/4"	1"				1-1/4"	1-1/4"	1-1/4"	R18	60.33	7.95	14.2	12.7	5.23	1.5
1-1/2"											R19	65.10	7.95	14.2	12.7	5.23	1.5
	1-1/2"	1-1/2"	1-1/2"	1-1/2"				1-1/2"	1-1/2"	1-1/2"	R20	68.28	7.95	14.2	12.7	5.23	1.5
					1-1/4"						R21	72.24	11.13	17.5	16	7.75	1.5
2"											R22	82.55	7.95	14.2	12.7	5.23	1.5
	2"			1-1/2"				2"			R23	82.55	11.13	17.5	16	7.75	1.5
		2"	2"						2"	2"	R24	95.25	11.13	17.5	16	7.75	1.5
2-1/2"											R25	101.60	7.96	14.2	12.7	5.23	1.5
	2-1/2"			2"				2-1/2"			R26	101.6	11.13	17.5	16	7.75	1.5
		2-1/2"	2-1/2"						2-1/2"	2-1/2"	R27	107.95	11.13	17.5	16	7.75	1.5
				2-1/2"							R28	111.13	12.70	19.1	17.5	8.66	1.5
3"											R29	114.30	7.95	14.2	12.7	5.23	1.5
	3"										R30	117.48	11.13	17.5	16.0	7.75	1.5
	3"	3"						3"	3"		R31	123.83	11.13	17.5	16.0	7.75	1.5
				3"							R32	127.00	12.70	19.1	17.5	8.66	1.5
3-1/2"											R33	131.78	7.95	14.2	12.7	5.23	1.5
	3-1/2"										R34	131.78	11.13	17.5	16.0	7.75	1.5
			3"							3"	R35	136.53	11.13	17.5	16.0	7.75	1.5
4"											R36	149.23	7.95	14.2	12.7	5.23	1.5
	4"	4"						4"	4"	3-1/2"	R37	149.23	11.13	17.5	16	7.75	1.5
				4"							R38	157.18	15.88	22.4	20.6	10.49	1.5
				4"						4"	R39	161.93	11.13	17.5	16.0	7.75	1.5
5"											R40	171.45	7.95	14.2	12.7	5.23	1.5
	5"	5"						5"	5"		R41	180.98	11.13	17.5	16.0	7.75	1.5
				5"							R42	190.5	19.05	25.4	23.9	12.32	1.5
6"											R43	193.68	7.95	14.2	12.7	5.23	1.5
				5"						5"	R44	193.68	11.13	17.5	16.0	7.75	1.5
	6"	6"						6"	6"		R45	211.15	11.13	17.5	16.0	7.75	1.5
				6"						6"	R46	211.15	12.70	19.1	17.5	8.66	1.5
				6"							R47	228.60	19.05	25.4	23.9	12.32	1.5
8"											R48	247.65	7.95	14.2	12.7	5.23	1.5
	8"	8"						8"	8"		R49	269.88	11.13	17.5	16.0	7.75	1.5
				8"						8"	R50	269.88	15.88	22.4	20.6	10.49	1.5
				8"							R51	279.40	22.23	28.7	26.9	14.81	1.5
10"											R52	304.80	7.95	14.2	12.7	5.23	1.5
	10"	10"						10"	10"		R53	323.85	11.13	17.5	16.0	7.75	1.5
				10"						10"	R54	323.85	15.88	22.4	20.6	10.49	1.5
				10"							R55	342.90	28.58	36.6	35.1	19.81	2.3
12"											R56	381.00	7.95	14.2	12.7	5.23	1.5
	12"	12"				12"	12"	12"	12"		R57	381.00	11.13	17.5	16.0	7.75	1.5
				12"							R58	381.00	22.23	28.7	26.9	14.81	1.5
14"											R59	398.88	7.95	14.2	12.7	5.23	1.5
				12"							R60	406.4	31.75	39.6	38.1	22.33	2.3
	14"					14"		14"	14"		R61	419.10	11.13	17.5	16.0	7.75	1.5
		14"					14"				R62	419.10	15.88	22.4	20.6	10.49	1.5
				14"							R63	419.1	25.4	33.3	31.8	17.3	2.3
16"											R64	454.03	7.95	14.2	12.7	5.23	1.5
	16"					16"		16"			R65	469.90	11.13	17.5	16.0	7.75	1.5
		16"					16"		16"		R66	469.90	15.88	22.4	20.6	10.49	1.5
				16"							R67	469.90	28.58	36.6	35.1	19.81	2.3
18"											R68	517.53	7.95	14.2	12.7	5.23	1.5
	18"					18		18"			R69	533.40	11.13	17.5	16	7.75	1.5
		18"					18"		18"		R70	533.40	19.05	25.4	23.9	12.32	1.5
				18"							R71	533.40	28.58	36.6	35.1	19.81	2.3

金屬環接型墊片尺寸表

單位:mm

法蘭尺寸/壓力									尺寸						
ASME-ANSI B16.5			ASME B16-47A			API16B			環號	P	A	B	H	C	R1
150	300-600	900	1500	150	300-600	900	2000	3000							
20"									R72	558.80	7.95	14.2	12.7	5.23	1.5
	20"				20"		20"		R73	584.20	12.7	19.1	17.5	8.66	1.5
		20"				20"		20"	R74	584.20	19.05	25.4	23.9	12.32	1.5
			20"						R75	584.20	31.75	39.6	38.1	22.33	2.3
24"									R76	673.1	7.95	14.2	12.7	5.23	1.5
	24"				24"				R77	692.15	15.88	22.4	20.6	10.49	1.5
		24"				24"			R78	692.15	25.40	33.3	31.8	17.3	2.3
			24"						R79	692.15	34.93	44.5	41.4	24.82	2.3
				22"					R80	615.95	7.95		12.7	5.23	1.5
					22"				R81	635.00	14.3		19.1	9.58	1.5
									R82	57.15	11.13		16.0	7.75	1.5
									R84	63.50	11.13		16.0	7.75	1.5
									R85	79.38	12.7		17.5	8.66	1.5
									R86	90.50	15.88		20.6	10.49	1.5
									R87	100.03	15.88		20.6	10.49	1.5
									R88	123.83	19.05		23.9	12.32	1.5
									R89	114.30	19.05		23.9	12.32	1.5
									R90	155.58	22.23		26.9	14.81	1.5
									R91	260.35	31.75		38.1	22.33	2.3
									R92	228.60	11.13	17.5	16.0	7.75	1.5
					26"				R93	749.30	19.05		23.9	12.32	1.5
					28"				R94	800.10	19.05		23.9	12.32	1.5
					30"				R95	857.25	19.05		23.9	12.32	1.5
					32"				R96	914.40	22.23		26.9	14.81	1.5
					34"				R97	965.2	22.23		26.9	14.81	1.5
					36"				R98	1022.35	22.23		26.9	14.81	1.5
							8"	8"	R99	234.95	11.13		16.0	7.75	1.5
						26"			R100	749.30	28.58		35.1	19.81	2.3
						28"			R101	800.10	31.75		38.1	22.33	2.3
						30"			R102	857.25	31.75		38.1	22.33	2.3
						32"			R103	914.40	31.75		38.1	22.33	2.3
						34"			R104	965.20	34.93		41.4	24.82	2.3
						36"			R105	1022.35	34.93		41.4	24.82	2.3

備註:※R30 只適用於重疊法蘭。

※以上尺寸根據ASME B16.20API std 6A.EN 12560-5。

橢圓形
Oval

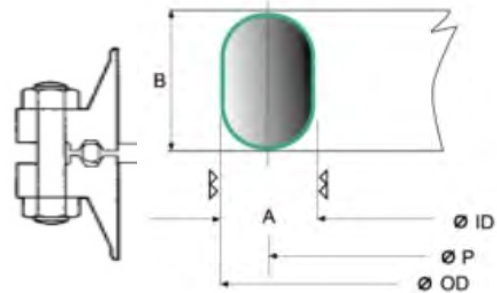

八角形
Octagonal

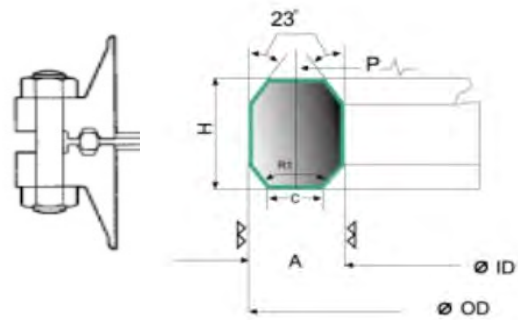

公差	厘米(mm)	英吋(inch)
A,C(RJ的寬)	+ / -0.20	+ / -0.008
B,H(RJ的高)	+1.3, -0.5	+ 0.05/-0.02
P(平均環中心直徑)	+ / 0.18	+ / -0.007
23°角	+ / - 0 deg 30 min	
R1(環半徑)	+ / 0.5	+ / -0.02











金屬 / 半金屬系列

齒形複合墊片

Kammprofile Gasket

齒型複合墊片結合鋸齒狀金屬芯和軟飾面，具有高度可壓縮性和適型性，強度足以承受惡劣的操作條件。最初是為夾套墊片設計，磨損熱交換器的最佳選擇。主要用於墊片寬度通常受到限制的容器，經常被用於使用金屬夾套墊圈的應用升級，提高密封性、易於安裝和重複使用的可能性。安裝所需的密封應力低、適用於多種化學品、高溫高壓、可製造用於窄法蘭。

型式和材質：

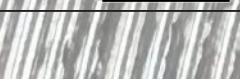
代號	型式	剖面	金屬材質	
OL#700	金屬平板		SOFTIRON CARBON STEEL	NICKEL 200 INCONEL 600 625
OL#701	基本式		304SS 304LSS	INCOLOY 800 825 TITANIUM
OL#702	可拆外環式		316SS 316LSS	HASTELLOY B2/B3 HASTELLOY C276
OL#703	外環式		316TISS 317LSS	HASTELLOY C22 ALUMINUM
OL#704	內環式		321SS 347SS	COPPER BRONZE
OL#705	可拆外環式 (有內環)		410SS 904LSS	SILVER ZIRCONIUM
OL#706	內外環式		5Cr-0.5Mo(F5) MONEL 400	DUPLEX 31803/32205 ALLOY 20
OL#707	雙齒形			OTHERS
OL#801	內溝凸面型			
OL#802	內溝凸面型 可拆外環型			
OL#803	內溝凸面型 外環型			

金屬 / 半金屬系列

齒形複合墊片

表面材質	石墨	膨體四氟	雲母
溫度 (C%)	-200 450(一般) -200 650(低氧)	-200~260	-100~1000
壓力 Bar	400	200	20

法蘭面	Flat Face	Raised Face	Tongue and Groove
建議選用型式	702	702	701
	703	703	801
	704	704	
	705	705	
	706	706	
	707	707	
	802	802	
	803	803	

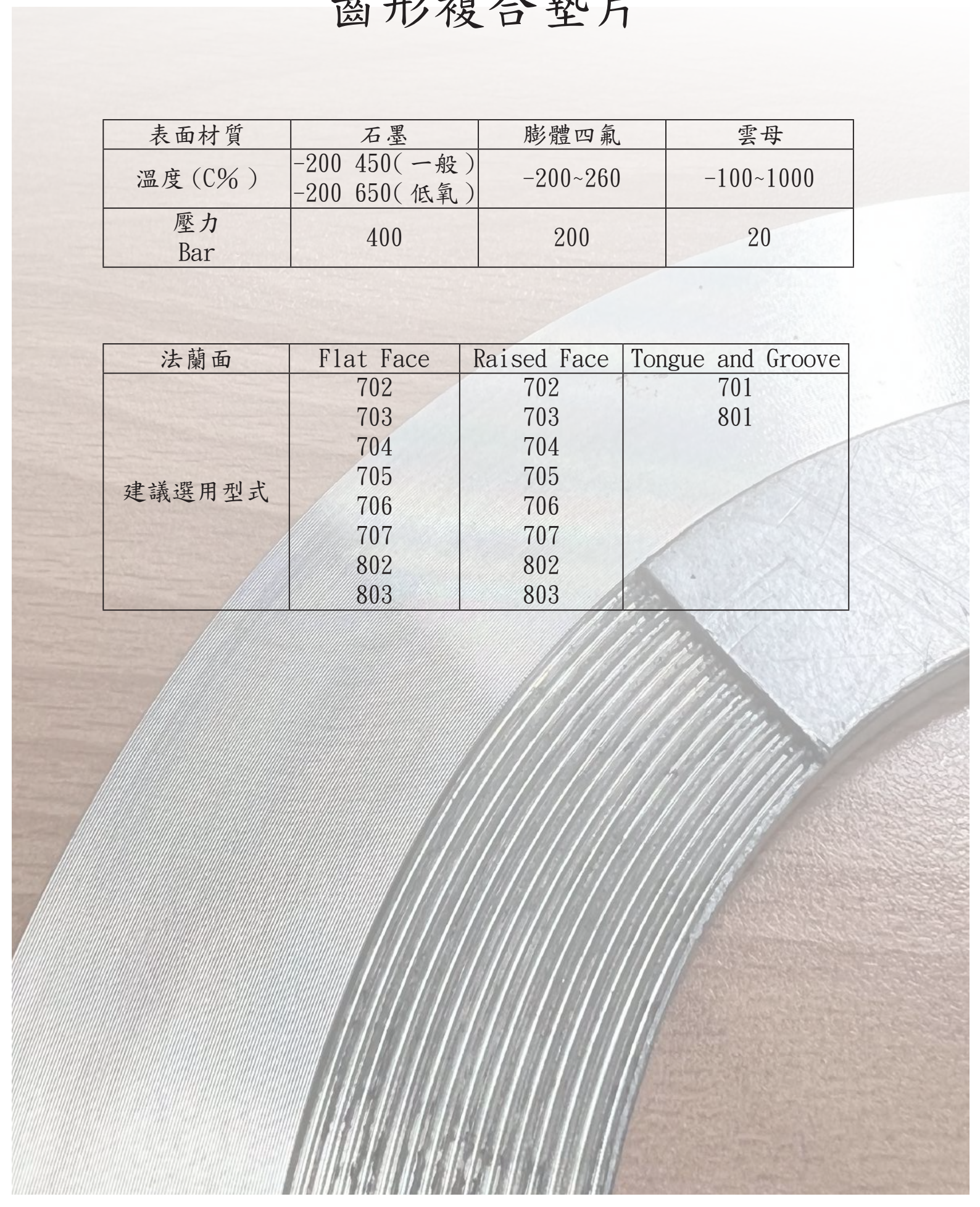

四氟系列

純四氟墊片 PTFE Gasket

O#7500 聚四氟乙烯

原始級 PTFE 墊片由 100% 純材料製成，大多數範圍均可使用。它非常柔軟且易於成型，通常用於耐化學腐蝕的密封件和墊圈。

PTFE 墊片產品具有耐化學性可以使用在衛生和無污染化學廠、煉油廠、食品廠及製藥廠。

聚四氟乙烯：具有許多特殊的功能

出色的耐化學性。

無腐蝕、不污染、無污染、無潤濕。

可以在從 -100°C 到 $+260^{\circ}\text{C}$ 的溫度下高效工作，最高使用壓力為 10 bar。

純聚四氟乙烯具有出色的電氣和熱絕緣性。



O#7530

由聚四氟乙烯組成，這是一種高分子量聚合物，由機器切割四氟外層，加輥壓成 V 形後包覆非石棉或其他材質墊片加工而成。PTFE 以極低的摩擦係數、出色的耐高溫和耐腐蝕性材料而聞名，幾乎可以抵抗所有酸性和腐蝕性物質。

應用：用於不能受污染或變色需要高純度原料的地方，例如食品和飲料行業。

通常用於：

1. 食品和飲料加工和行業
2. 基本上在任何化學應用中

四氟系列

純四氟墊片

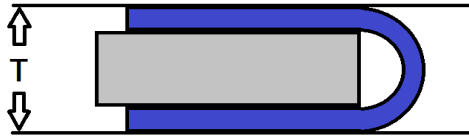

0#7531

具有非常低的摩擦係數、於高溫和低溫表現能力良好，幾乎可以抵抗所有酸和腐蝕性物質。它柔韌且極其柔軟，因此可以有效地貼合不規則法蘭。

應用於：UV 水淨化系統、廢氣傳感器、食品加工設備中的泵和閥門、電氣絕緣（例如：電容器中的單獨導電表面）

墊圈、墊圈、環、密封件和墊片：

石化、食品加工、生物技術和製藥行業、紙漿和造紙、發電



0#7535

由機器切割成內徑邊緣成工形的四氟外層，包覆非石棉或其他材質墊片加工而成，適合生產內墊材質較厚及使用於有磨蝕性的流體。一種軟墊片材料，專為在極端腐蝕性到酸性化學品中的高性能服務而設計。符合粗糙的密封表面，但壓縮成極其堅韌的墊圈，形成緊密、持久的密封。膨脹的 Virgin PTFE 本身沒有結構上的弱點，因為它具有均勻且高原纖化的微觀結構，在所有方面上具有相同的拉伸強度。

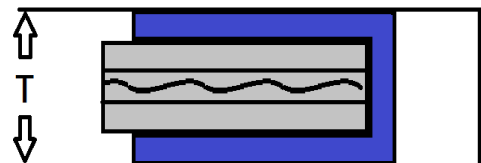
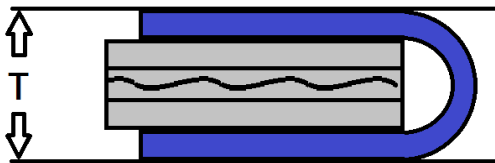

0#7531 及 0#7535 包覆材料中間也可加入金屬波浪墊片增強（普遍材質為 316SS），三層或三層以上的多重密封具有良好的壓縮特性，波浪墊片具回彈性，鎖緊力需較低，適用於搪玻璃及 FRP 管道密封。最高使用壓力為 40bar。中間金屬如需其他特殊金屬材質，亦可接受客製化。

四氟系列

改性填充四氟墊片

Filled PTFE Sheet Gasket

以雙向聚四氟乙烯為基礎的板材，結合了優異的耐化學性和高密封性。

本系列板材可以從低溫運行至 260°C，且可以接觸所有具有腐蝕性的流體。



雙軸取向結構



微孔結構







多層版本

 <p>S11</p>	 德國勞氏船級協會	 防火 API 6FB 認證
	 德國氧氣認證	 美國食品藥品管理局認證
	 德國煤氣和水行業協會認證	 德國檢驗微量洩漏 & 排放
 <p>S33</p>	 德國勞氏船級協會	 德國檢驗微量洩漏 & 排放
	 德國煤氣和水行業協會認證	 美國食品藥品管理局認證
	 德國勞氏船級協會	 德國檢驗微量洩漏 & 排放
 <p>S50</p>	 德國煤氣和水行業協會認證	 美國食品藥品管理局認證
	 德國勞氏船級協會	 德國檢驗微量洩漏 & 排放

四氟系列

改性填充四氟墊片

型號 SICHEM®		S11	S33	S50	S92
顏色					
組成		複合式鐵氟龍 二氧化矽填料	複合式鐵氟龍 硫酸鋇填料	複合式鐵氟龍 玻璃微珠填料	複合式鐵氟龍 石墨
密度		2.2	2.8	1.4	1.45
最低 / 最高工作溫度°C		-260~260	-260~260	-260~260	-260~260
最高工作壓力 (BAR)		80	80	50	50
壓力溫度最大值 (BAR*°C) (Thk0.8-2.0mm)		12000	12000	12000	12000
壓力溫度最大值 (BAR*°C) (Thk3.0mm)		8500	8500	8500	8500
洩漏率 (mg*s ⁻¹ -m ⁻¹) DIN 3535-6		<0.05	<0.005	<0.05	<0.005
潛變鬆弛 (%) DIN 3535-6		<24	<28	<19	<27
壓縮率 (%) DIN 3535-6		>4	>4.3	>32	>42
復原率 (%) DIN 3535-6		>1.7	>2.7	>7	>12
酸鹼值適用範圍		0~14	0~14	0~14	0~14
尺寸 規格	長度*寬度 (mm)	1500*1500 1750*1750	1500*1500 1750*1750	1500*1500 1750*1750	1500*1500 1750*1750
	厚度 (mm)	0.75/1.0/2.0/2.5 /3.0/4.0/5.0/6.0	0.75/1.0/2.0/2.5 /3.0/4.0/5.0/6.0	0.75/1.0/2.0/2.5 /3.0/4.0/5.0/6.0	0.75/1.0/2.0/2.5 /3.0/4.0/5.0/6.0
公差	長度*寬度 (mm)	+/-50	+/-50	+/-50	+/-50
	厚度 (%)	+/-10	+/-10	+/-10	+/-10

鐵氟龍墊料化學兼容性指南

● 適用 ● 不適用 ● 取決於操作條件 ○ 無參考數據

英文名稱	中文名稱	S11	S33	S50	英文名稱	中文名稱	S11	S33	S50
Acetaldehyde	乙醛	●	●	●	Bis(2-chloroethyl)ether	雙(2-氯乙基)醚	●	●	●
Acetamide	乙酰胺	●	●	●	Bis(chloromethyl)ether	二氯甲基醚	●	●	●
Acetic Acid	乙酸	●	●	●	Bis(2-ethylhexyl)phthalate	鄰苯二甲酸二	●	●	●
Acetic Anhydride	醋酸酐	●	●	●	Black Sulfate Liquor	黑色硫酸鹽酒	●	●	●
Acetone	丙酮	●	●	●	Blast Furnace Gas	高爐煤氣	●	●	●
Acetonitrile	乙腈	●	●	●	Bleach (Sodium Hypochlorite)	漂白劑(次氯酸鈉)	●	●	●
Acetophenone	苯乙酮	●	●	●	Boiler Feed Water	鍋爐給水	●	●	●
Acetylaminofluorene	乙酰氨基芴	●	●	●	Borax	硼砂	●	●	●
Acetylene	乙炔	●	●	●	Boric Acid	硼酸	●	●	●
Acrolein	丙烯醛	●	●	●	Brine (Sodium Chloride)	鹽水(氯化鈉)	●	●	●
Acrylamide	丙烯酰胺	●	●	●	Bromine	溴	●	●	●
Acrylic Acid	丙烯酸	●	●	●	Bromine Trifluoride	氟化溴	●	●	●
Acrylic Anhydride	丙烯酸酐	●	●	●	Bromoform	三溴甲烷	●	●	●
Acrylonitrile	丙烯腈	●	●	●	Bromomethane	溴甲烷	●	●	●
Adipic Acid	己二酸	●	●	●	Butadiene	丁二烯	●	●	●
Adiponitrile	己二腈	●	●	●	Butane	丁烷	●	●	●
Air	空氣	●	●	●	Butanone	丁酮	●	●	●
Allyl Acetate	乙酸烯丙酯	●	●	●	Butyl Acetate	醋酸丁酯	●	●	●
Allyl Chloride	氯丙烯	●	●	●	Butyl Alcohol, Butanol	丁醇·丁醇	●	●	●
Allyl Methacrylate	甲基丙烯酸烯丙酯	●	●	●	Butyl Amine	丁基胺	●	●	●
Aluminum Chloride	氯化鋁	●	●	●	tert-Butyl Amine	叔丁基胺	●	●	●
Aluminum Fluoride	氟化鋁	●	●	●	Butyl Methacrylate	甲基丙烯酸丁酯	●	●	●
Aluminum Hydroxide (Solid)	氫氧化鋁(固體)	●	●	●	Butyric Acid	丁酸	●	●	●
Aluminum, Molten	熔化鋁	○	○	○	Calcium Bisulfite	亞硫酸氫鈣	●	●	●
Aluminum Nitrate	硝酸鋁	●	●	●	Calcium Chloride	氯化鈣	●	●	●
Aluminum Sulfate	硫酸鋁	●	●	●	Calcium Cyanamide	氰氨化鈣	●	●	●
Alums	礬	●	●	●	Calcium Hydroxide	氫氧化鈣	○	●	●
Aminodiphenyl	氨基聯苯	●	●	●	Calcium Hypochlorite	次氯酸鈣	●	●	●
Ammonia, Gas, 70°C and below	氨·天然氣·70°C以下	●	●	●	Calcium Nitrate	硝酸鈣	●	●	●
Ammonia, Gas, Above 70°C	氨·天然氣·70°C以上	●	●	●	Cane Sugar Liquors	甘蔗糖液	●	●	●
Ammonia, Liquid, Anhydrous	氨·無水液體	●	●	●	Caprolactam	己內酰胺	●	●	●
Ammonium Chloride	氯化銨	●	●	●	Captan	克菌丹	●	●	●
Ammonium Hydroxide	氫氧化銨	●	●	●	Carbaryl	西維因	●	●	●
Ammonium Nitrate	硝酸銨	●	●	●	Carbolic Acid, Phenol	石炭酸·苯酚	●	●	●
Ammonium Phosphate, Monobasic	磷酸二銨	●	●	●	Carbon Dioxide, Dry	二氧化碳·乾	●	●	●
Ammonium Phosphate, Dibasic	磷酸銨·磷酸氫二銨	●	●	●	Carbon Dioxide, Wet	二氧化碳·濕	●	●	●
Ammonium Phosphate, Tribasic	磷酸銨·三元	●	●	●	Carbon Disulfide	二硫化碳	●	●	●
Ammonium Sulfate	硫酸銨	●	●	●	Carbon Monoxide	一氧化碳	●	●	●
Amyl Acetate	乙酸異戊酯	●	●	●	Carbon Tetrachloride	四氯化碳	●	●	●
Amyl Alcohol	戊醇	●	●	●	Carbonic Acid	碳酸	●	●	●
Aniline, Aniline Oil	苯胺·苯胺油	●	●	●	Carbonyl Sulfide	羰基硫	●	●	●
Aniline Hydrochloride	苯胺鹽酸鹽	○	○	○	Castor Oil	蓖麻油	●	●	●
Aniline Dyes	苯胺染料	●	●	●	Catechol	鄰苯二酚	●	●	●
Anisidine	茴香胺	●	●	●	Caustic Soda	苛性鈉	●	●	●
Antimony trichloride	三氯化銻	●	●	●	Cetane (Hexadecane)	十六烷	●	●	●
Aqua Regia	王水	●	●	●	China Wood Oil	中國木油	●	●	●
Aroclors or Arochlor	氯化二苯或氯化三聯苯	●	●	●	Chloramben	除草劑	●	●	●
Aromatic Hydrocarbons	芳香烴	○	○	○	Chlorazotic Acid (Aqua Regia)	氯唑酸(王水)	●	●	●
Arsenic Acid	砷酸	●	●	●	Chlordane	氯丹	●	●	●
Arsenous Acid	亞砷酸	●	●	●	Chlorinated Solvents, Dry	氯化溶劑·乾	●	●	●
Asphalt	瀝青	●	●	●	Chlorinated Solvents, Wet	氯化溶劑·濕	●	●	●
Aviation Gasoline	航空汽油	●	●	●	Chlorine, Dry	氯氣·乾	●	●	●
Barium Chloride	氯化鋇	●	●	●	Chlorine, Wet	氯氣·濕	●	●	●
Barium Hydroxide	氫氧化鋇	●	●	●	Chlorine Dioxide	二氧化氯	●	●	●
Barium Sulfide	硫化鋇	●	●	●	Chlorine Trifluoride	三氯化氯	●	●	●
Baygon	殺蟲劑	●	●	●	Chloroacetic Acid	氯乙酸	●	●	●
Beer	啤酒	●	●	●	Chloroacetophenone	氯苯乙	●	●	●
Benzaldehyde	苯甲醛	●	●	●	Chlorobenzene	氯苯	●	●	●
Benzene, Benzol	苯·苯酚	●	●	●	Chlorobenzilate	乙酯殺蟻醇	●	●	●
Benzene Sulphonic Acid	苯磺酸	●	●	●	Chloroethane	氯乙烷	●	●	●
Benzidine	聯苯胺	●	●	●	Chloroethylene	氯乙烯	●	●	●
Benzoic Acid	苯甲酸	●	●	●	Chloroform	氯仿	●	●	●
Benzonitrile	苯甲腈	●	●	●	Chloromethyl Methyl Ether (CMME)	氯甲醚	●	●	●
Benzoquinones	苯醌	●	●	●	Chloronitrous Acid (Aqua Regia)	氯硝酸(王水)	●	●	●
Benzotrichloride	三氯甲苯	●	●	●	Chloroprene	氯丁	●	●	●
Benzoyl Chloride	苯甲酰氯	●	●	●	Chlorosulfonic Acid	氯磺酸	●	●	●
Benzyl Alcohol	苯甲醇	●	●	●	Chromic Acid	鉻酸	●	●	●
Benzyl Chloride	氯化苄	●	●	●	Chromic Anhydride	鉻酸酐	●	●	●
Bio-diesel (B100)	生物柴油(B100)	●	●	●	Chromium Trioxide	三氧化鉻	●	●	●
Biphenyl	聯苯	●	●	●	Citric Acid	檸檬酸	●	●	●

英文名稱	中文名稱	S11	S33	S50	英文名稱	中文名稱	S11	S33	S50
Coke Oven Gas	焦爐煤氣	●	●	●	Fluorine, Liquid	氟·液態	●	●	●
Copper Chloride	氯化銅	●	●	●	Fluorine Dioxide	氟氧化鈦	●	●	●
Copper Sulfate	硫酸銅	●	●	●	Formaldehyde	甲醛	●	●	●
Corn Oil	玉米油	●	●	●	Formic Acid	蟻酸	●	●	●
Cotton Seed Oil 10	棉花籽油10	●	●	●	Fuel Oil	燃料油	●	●	●
Creosote	雜酚油	●	●	●	Fuel Oil, Acid	燃料油·酸性	●	●	●
Cresols, Cresylic Acid	甲酚·甲苯基酸	●	●	●	Gasoline, Refined	汽油·精製	●	●	●
Crotonic Acid	巴豆酸	●	●	●	Gelatin	明膠	●	●	●
Crude Oil	原油	●	●	●	Glucose	葡萄糖	●	●	●
Cumene	異丙苯	●	●	●	Glycerine, Glycerol	甘油·甘油	●	●	●
Cyclohexane	環己	●	●	●	Glycol	乙二醇	●	●	●
Cyclohexanol	環己醇	○	○	○	Grain Alcohol	糧食酒	●	●	●
Cyclohexanone	環己酮	●	●	●	Grease, Petroleum Base	潤滑脂·石油基	●	●	●
Diazomethane	重氮甲烷	●	●	●	Green Sulfate Liquor	綠酒硫酸	●	●	●
Dibenzofuran	二苯並呋喃	●	●	●	Heptachlor	七氯	●	●	●
Dibenzylether	二苄	●	●	●	Heptane	庚烷	●	●	●
Dibromo chloropropane	二溴氯丙烷	●	●	●	Hexachlorobenzene	六氯苯	●	●	●
Dibromoethane	二溴乙烷	●	●	●	Hexachlorobutadiene	六氯丁二烯	●	●	●
Dibutyl Phthalate	鄰苯二甲酸二丁酯	●	●	●	Hexachlorocyclopentadiene	六氯環戊二烯	●	●	●
Dibutyl Sebacate	癸二酸二丁酯	●	●	●	Hexachloroethane	六氯乙烷	●	●	●
Dichlorobenzene	二氯苯	●	●	●	Hexadecane	十六烷	●	●	●
Dichlorobenzidene	二氯聯苯胺	●	●	●	Hexamethylene Diisocyanate	二異氰酸酯	●	●	●
Dichloroethane	二氯乙烷	●	●	●	Hexamethylphosphoramide	六甲基	●	●	●
Dichloroethylene	二氯乙烯	○	○	○	Hexane	己烷	●	●	●
Dichloroethyl Ether	二氯乙醚	●	●	●	Hexone	異己酮	●	●	●
Dichloromethane	二氯甲烷	●	●	●	Hydraulic Oil, Mineral	液壓油·礦物	●	●	●
Dichloropropane	二氯丙烷	●	●	●	Phosphate Esters	磷酸酯	●	●	●
Dichloropropene	氯丙烯	●	●	●	Hyorazine	聯氨	●	●	●
Dichlorvos	敵敵畏	●	●	●	Hydrobromic Acid	氫溴酸	●	●	●
Diesel Oil	柴油	●	●	●	Hydrochloric Acid	鹽酸	●	●	●
Diethanolamine	二乙醇胺	●	●	●	Hydrochloric Acid, dry	鹽酸·乾	○	○	○
Diethylaniline	二乙基苯胺	●	●	●	Hydrochloric Acid 20%	鹽酸20%	○	○	○
Diethyl Carbonate	碳酸二乙酯	●	●	●	Hydrocyanic Acid	氫氰酸	●	●	●
Diethyl Sulfate	硫酸二乙酯	●	●	●	Hydrofluoric Acid, Anhydrous	氫氟酸·無水	●	●	●
Dimethoxybenzidene	二甲氧基	●	●	●	Hydrofluoric Acid, Less than 65%, Above 70°C	氫氟酸·小於65%·大於70°C	●	●	●
Dimethylaminoazobenzene	二甲胺基	●	●	●	Hydrofluoric Acid, 65% to Anhydrous, Above 70°C	氫氟酸·無水65%·大於70°C	●	○	●
Dimethyl Aniline	甲基苯胺	●	●	●	Hydrofluoric Acid, Up to Anhydrous, 70°C & below	氫氟酸·至無水·大於70°C	●	●	●
Dimethylbenzidine	二甲基聯	●	●	●	Hydrofluorosilicic Acid	氟矽酸	●	●	●
Dimethyl Carbamoyl Chloride	二甲基氨基甲酰氯	●	●	●	Hydrofluosilicic Acid	氟矽酸	●	●	●
Dimethyl Ether	二甲醚	●	●	●	Hydrogen	氫	●	●	●
Dimethylformamide	二甲基甲酰胺	●	●	●	Hydrogen Bromide	溴化氫	●	●	●
Dimethyl Phthalate	鄰苯二甲酸二甲酯	●	●	●	Hydrogen Fluoride	氟化氫	●	●	●
Dimethyl Sulfate	硫酸二甲酯	●	●	●	Hydrogen Peroxide, 1 0%	過氧化氫·10%	●	●	●
Dinitrophenol	二硝基苯酚	●	●	●	Hydrogen Peroxide, 1 0-90%	過氧化氫·10~90%	●	●	●
Dinitrotoluene	二硝基甲苯	●	●	●	Hydrogen Sulfide, Dry or Wet	硫化氫·乾或濕	●	●	●
Dioxane	二惡烷	●	●	●	Hydroquinone	對苯二酚	●	●	●
Diphenylhydrazine	二苯肼	●	●	●	Iodine Pentafluoride	五氟化碘	○	○	○
Epichlorohydrin	環氧氯丙烷	●	●	●	Iodomethane	碘甲烷	●	●	●
E85 (85% Ethanol, 15% Gas)	E85 (85%乙醇·15%氣體)	●	●	●	Isobutane	異丁烷	●	●	●
Epoxybutane	環氧丁烷	●	●	●	Isooctane	異辛烷	●	●	●
Ethane	乙烷	●	●	●	Isophorone	異佛爾酮	●	●	●
Ethers	醚	●	●	●	Isopropyl Alcohol	異丙Alcohol	●	●	●
Ethyl Acetate	醋酸乙酯	●	●	●	Jet Fuels	噴氣燃料	●	●	●
Ethyl Acrylate	丙烯酸乙酯	●	●	●	Kerosene	煤油	●	●	●
Ethyl Alcohol	乙醇	●	●	●	Lacquer Solvents	漆溶劑	●	●	●
Ethylbenzene	乙苯	●	●	●	Lacquers	漆	●	●	●
Ethyl Carbamate	氨基甲酸乙酯	●	●	●	Lactic Acid, 70°C and below	乳酸·小於等於70°C	●	●	●
Ethyl Cellulose	乙基纖維素	●	●	●	Lactic Acid, Above 70°C	乳酸·大於70°C	●	●	●
Ethyl Chloride	氯乙烷	●	●	●	Lime Saltpeper (Calcium Nitrates)	石灰硝石(硝酸鈣)	●	●	●
Ethyl Ether	乙醚	●	●	●	Lindane	林丹	●	●	●
Ethyl Hexoate	乙基己酸	●	●	●	Linseed Oil	亞麻籽油	●	●	●
Ethylene	乙烯	●	●	●	Liquified Petroleum Gas	液化石油氣	●	●	●
Ethylene Bromide	溴乙烯	●	●	●	Lithium Bromide	溴化鋰	●	●	●
Ethylene Dibromide	二溴乙烷	●	●	●	Lithium, Elemental	鋰·元素	●	●	●
Ethylene Dichloride	二氯乙烷	●	●	●	Lubricating Oils, Refined	潤滑油·精	●	●	●
Ethylene Glycol	乙二醇	●	●	●	Lubricating Mineral or Petroleum Types	潤滑礦產或石油類型	●	●	●
Ethyleneimine	乙烯亞胺	○	○	○	Sour	酸	●	●	●
Ethylene Oxide	環氧乙烷	●	●	●	Lye	鹼液	●	●	●
Ethylene Thiourea	乙撐硫脲	●	●	●	Magnesium Chloride	氯化鎂	●	●	●
Ethylidine Chloride	次乙基氯化物	●	●	●	Magnesium Hydroxide	氫氧化鎂	●	●	●
Ferric Chloride	三氯化鐵	●	●	●	Magnesium Sulfate	硫酸鎂	●	●	●
Ferric Phosphate	磷酸鐵	●	●	●	Maleic Acid	馬來酸	●	●	●
Ferric Sulfate	硫酸鐵	○	○	○	Maleic Anhydride	順酐	●	●	●
Fluorine, Gas	氟·燃態	○	○	○	Mercuric Chloride	氯化汞	●	●	●

英文名稱	中文名稱	S11	S33	S50	英文名稱	中文名稱	S11	S33	S50
Mercury	汞	●	●	●	Petroleum Oils, Refined	石油·精製	●	●	●
Methane	甲烷	●	●	●	Phenol	苯酚	●	●	●
Methanol, Methyl Alcohol	甲醇·甲醇	●	●	●	Phenylenediamine	苯二胺	●	●	●
Methoxychlor	甲氧	●	●	●	Phosgene	光氣	●	●	●
Methylacrylic Acid	甲基丙烯酸	●	●	●	Phosphate Esters	磷酸酯	●	●	●
Methyl Alcohol	甲醇	●	●	●	Phosphine	磷	●	●	●
Methylaziridine	甲基氮丙啶	○	●	○	Phosphoric Acid, Crude	磷酸·原油	●	●	●
Methyl Bromide	甲基溴	●	●	●	Phosphoric Acid, Pure, Less than 45%	磷酸·純·小於45%	●	●	●
Methyl Chloride	氯甲烷	●	●	●	Phosphoric Acid, Pure, Above 45%	磷酸·純·大於45%	●	●	●
Methyl Chloroform	甲基氯仿	●	●	●	Phosphoric Acid, Pure Above 45%, Above 70°C	磷酸·大於45%·大於70°C	●	●	●
4,4-Methylene-Bis(2-chloroaniline)	4,4-亞甲基-雙(2-氯苯胺)	●	●	●	Phosphorus, Elemental	磷·元素	●	●	●
Methylene Chloride	二氯甲烷	●	●	●	Phosphorus Pentachloride	五氯化磷	●	●	●
Methylene Dianiline	亞甲基二苯胺	●	●	●	Phthalic Acid	鄰苯二甲酸	●	●	●
Methylene Diphenyldiisocyanate	亞甲基二苯基	●	●	●	Phthalic Anhydride	苯酐	●	●	●
Methyl Ethyl Ketone (MEK)	甲基乙基酮	●	●	●	Picric Acid, Molten	苦味酸·熔融	○	○	○
Methyl Hydrazine	甲基肼	●	●	●	Picric Acid, Water Solution	苦味酸·耐水解	●	●	●
Methyl Iodide	碘甲烷	●	●	●	Pinene	蒎烯	●	●	●
Methyl Isobutyl Ketone (MIBK)	甲基異丁基酮	●	●	●	Piperidine	哌啶	●	●	●
Methyl Isocyanate	異氰酸甲酯	●	●	●	Polyacrylonitrile	聚丙烯腈	●	●	●
Methyl Methacrylate	甲基丙烯酸甲酯	●	●	●	Polychlorinated Biphenyls	多氯聯苯	●	●	●
Methyl Pyrrolidone	甲基吡咯烷酮	●	●	●	Potash, Potassium Carbonate	鉀肥·碳酸鉀	●	●	●
Methyl Tert. Butyl Ether (MTBE)	甲基叔丁基醚	●	●	●	Potassium Acetate	醋酸鉀	●	●	●
Milk	牛奶	●	●	●	Potassium Bichromate	重鉻酸鉀	●	●	●
Mineral Oils	礦物油	●	●	●	Potassium Chromate, Red	鉻酸鉀·紅	●	●	●
Molten Alkali Metals	熔融鹼金屬	●	●	●	Potassium Cyanide	氰化鉀	●	●	●
Monomethylamine	一甲胺	●	●	●	Potassium Dichromate	重鉻酸鉀	●	●	●
Muriatic Acid	鹽酸	●	●	●	Potassium, Elemental	鉀元素	●	●	●
Naphtha	石腦油	●	●	●	Potassium Hydroxide	氫氧化鉀	●	●	●
Naphthalene	萘	●	●	●	Potassium Iodide	碘化鉀	○	○	○
Naphthols	萘酚	●	●	●	Potassium Nitrate	硝酸鉀	●	●	●
Natural Gas	天然氣	●	●	●	Potassium Permanganate	高錳酸鉀	●	●	●
Nickel Chloride	氯化鎳	●	●	●	Potassium Sulfate	硫酸鉀	●	●	●
Nickel Sulfate	硫酸鎳	●	●	●	Producer Gas	作業中煤氣	●	●	●
Nitric Acid, Less than 30%	硝酸·小於30%	●	●	●	Propane	丙烷	●	●	●
Nitric Acid, Above 30%	硝酸·大於30%	●	●	●	Propane Sulfone	丙烷磺內酯	●	●	●
Nitric Acid, Crude	粗硝酸	●	●	●	Beta-Propiolactone	β-丙內酯	●	●	●
Nitric Acid, Red Fuming	發煙硝酸	●	●	●	Propionaldehyde	丙醛	●	●	●
Nitrobenzene	硝基苯	●	●	●	Propyl Alcohol	丙醇	●	●	●
Nitrobiphenyl	硝基	●	●	●	Propyl Nitrate	硝酸丙酯	●	●	●
Nitro-Butanol	硝基丁醇	●	●	●	Propylene	丙烯	●	●	●
Nitrocalcite (Calcium Nitrate)	硝酸鈣	●	●	●	Propylene Dichloride	二氯丙烯	●	●	●
Nitrogen	氮	●	●	●	Propylene Glycol	丙二醇	●	●	●
Nitrogen Tetroxide	四氧化二氮	●	●	●	Propylene Oxide	環氧丙烷	●	●	●
Nitrohydrochloric Acid (Aqua Regia)	硝酸鹽酸(王水)	●	●	●	Propylenimine	丙烯亞胺	○	●	○
Nitromethane	硝基甲烷	●	●	●	Prussic Acid, Hydrocyanic Acid	氫氰酸·氫氰酸	●	●	●
2-Nitro-2-Methyl Propanol	2-硝基-2-甲基丙醇	●	●	●	Pyridine	吡啶	●	●	●
Nitromuriatic Acid (Aqua Regia)	硝酸(王水)	●	●	●	Quinoline	喹啉	●	●	●
Nitrophenol	硝基苯酚	●	●	●	Quinone	醌	●	●	●
Nitropropane	硝基	●	●	●	Refrigerant type 10	製冷劑型號 10	●	●	●
Nitrosodimethylamine	亞硝胺	●	●	●	Refrigerant type 11	製冷劑型號 11	●	●	●
Nitroso Methylurea	氮甲基脲	●	●	●	Refrigerant type 12	製冷劑型號 12	●	●	●
Nitrosomorpholine	亞硝基	●	●	●	Refrigerant type 13	製冷劑型號 13	●	●	●
Norge Niter (Calcium Nitrate)	硝酸鎳(硝酸鈣)	●	●	●	Refrigerant type 13B1	製冷劑型號 13B1	●	●	●
Norwegian Saltpeter (Calcium Nitrate)	挪威硝(硝酸鈣)	●	●	●	Refrigerant type 21	製冷劑型號 21	●	●	●
Octadecyl Alcohol	十八烷醇	●	●	●	Refrigerant type 22	製冷劑型號 22	●	●	●
Octane	辛烷值	●	●	●	Refrigerant type 23	製冷劑型號 23	●	●	●
Oil, Petroleum	石油·工業油	●	●	●	Refrigerant type 31	製冷劑型號 31	●	●	●
Oils, Animal and Vegetable	動物油·植物油	●	●	●	Refrigerant type 32	製冷劑型號 32	●	●	●
Oleic Acid	油酸	●	●	●	Refrigerant type 112	製冷劑型號 112	●	●	●
Oleum	發煙硫酸	●	●	○	Refrigerant type 113	製冷劑型號 113	●	●	●
Orthodichlorobenzene	鄰二氯苯	●	●	●	Refrigerant type 114	製冷劑型號 114	●	●	●
Oxalic Acid	草酸	●	●	●	Refrigerant type 114B2	製冷劑型號 114B2	●	●	●
Oxygen, Gas (BAM Approval)	氧氣·煤氣(BAM批准)	●	○	●	Refrigerant type 115	製冷劑型號 115	●	●	●
Ozone	臭氧	○	○	○	Refrigerant type 123	製冷劑型號 123	●	●	●
Palmitic Acid	棕櫚酸	●	●	●	Refrigerant type 124	製冷劑型號 124	●	●	●
Paraffin	石蠟	●	●	●	Refrigerant type 125	製冷劑型號 125	●	●	●
Parathion	對硫磷	●	●	●	Refrigerant type 134a	製冷劑型號 134a	●	●	●
Paraxylene	對二甲苯	●	●	●	Refrigerant type 141b	製冷劑型號 141B	●	●	●
Pentachloronitrobenzene	五氯硝基苯	●	●	●	Refrigerant type 142b	製冷劑型號 142B	●	●	●
Pentachlorophenol	五氯酚	●	●	●	Refrigerant type 143a	製冷劑型號 143A	●	●	●
Pentane	戊烷	●	●	●	Refrigerant type 152a	製冷劑型號 152A	●	●	●
Perchloric Acid	高氯酸	●	●	●	Refrigerant type 218	製冷劑型號 218	●	●	●
Perchloroethylene	四氯乙烯	●	●	●	Refrigerant type 290 (Propane)	製冷劑型號 290(丙烷)	●	●	●
Petroleum Oils, Crude	石油·原油	●	●	●	Refrigerant type 500	製冷劑型號 500	●	●	●

英文名稱	中文名稱	S11	S33	S50	英文名稱	中文名稱	S11	S33	S50
Refrigerant type 502	製冷劑型號 502	●	●	●	Toluene Sulfonic Acid	甲苯磺酸	●	●	●
Refrigerant type 503	製冷劑型號 503	●	●	●	Toluidine	甲苯胺	●	●	●
Refrigerant type 507	製冷劑型號 507	●	●	●	Toxaphene	毒殺芬	●	●	●
Refrigerant type 717 (Ammonia)	製冷劑型號 717 (氨)	●	●	●	Transformer Mineral Oil	變壓器油	●	●	●
Refrigerant type 744(Carbon Dioxide)	製冷劑型號 744 (二氧化碳)	●	●	●	Transmission Fluid A	變速箱油A	●	●	●
Refrigerant type C316	製冷劑型號 C316	●	●	●	Trichloroacetic Acid	三氯乙酸	●	●	●
Refrigerant type C318	製冷劑型號 C318	●	●	●	Trichlorobenzene	三氯苯	●	●	●
Refrigerant type HP62	製冷劑型號 HP62	●	●	●	Trichloroethane	三氯乙烷	●	●	●
Refrigerant type HP80	製冷劑型號 HP80	●	●	●	Trichloroethylene	三氯乙烯	●	●	●
Refrigerant type HP81	製冷劑型號 HP81	●	●	●	Trichlorophenol	三氯	●	●	●
Salt Water	鹹水	●	●	●	Tricresylphosphate	磷酸三甲苯酯	●	●	●
Salt peter, Potassium Nitrate	硝石·硝酸鉀	●	●	●	Triethanolamine	三乙醇胺	●	●	●
Sewage	污水	●	●	●	Triethyl Aluminum	三乙基鋁	●	●	●
Silicon Oil	矽油	○	○	○	Triethylamine	三乙胺	●	●	●
Silver Nitrate	硝酸銀	●	●	●	Trifluralin	氟樂靈	●	●	●
Soda Ash, Sodium Carbonate	蘇打灰·碳酸鈉	●	●	●	Trimethylpentane	三甲基	●	●	●
Sodium Bicarbonate, Baking Soda	碳酸氫鈉·小蘇打	●	●	●	Turpentine	松節油	●	●	●
Sodium Bisulfate (Dry)	硫酸氫鈉(乾)	●	●	●	Urea, 70°C and below	尿素·小於等於70°C	●	●	●
Sodium Bisulfite	亞硫酸氫鈉	●	●	●	Urea, above 70°C	尿素·大於70°C	●	●	●
Sodium Chlorate	氯酸鈉	●	●	●	Varnish	漆	●	●	●
Sodium Chloride	氯化鈉	●	●	●	Vegetable Oil	植物油	●	●	●
Sodium Cyanide	氰化鈉	●	●	●	Vinager	醋	●	●	●
Sodium, Elemental	鈉元素	●	●	●	Vinyl Acetate	醋酸乙烯酯	●	●	●
Sodium Hydrogen Sulphite	亞硫酸氫鈉	○	○	○	Vinyl Bromide	溴乙烯	●	●	●
Sodium Hydroxide	氫氧化鈉	●	●	●	Vinyl Chloride	氯乙烯	●	●	●
Sodium Hypochlorite	次氯酸鈉	●	●	●	Vinylidene Chloride	偏二氯乙烯	●	●	●
Sodium Metaborate Peroxyhydrate	硼酸鈉過氧	●	●	●	Vinyl Methacrylate	甲基丙烯酸乙酯	●	●	●
Sodium Metaphosphate	偏磷酸鈉	●	●	●	Water, Acid Mine, with Oxidizing Salt	水·酸性礦井·用氧化鹽	●	●	●
Sodium Nitrate	硝酸鈉	●	●	●	Water, Acid Mine, No Oxidizing Salts	水·酸性礦井·無氧化鹽	●	●	●
Sodium Perborate	過硼酸鈉	●	●	●	Water, Distilled	水·蒸餾水	●	●	●
Sodium Peroxide	過氧化鈉	●	●	●	Return Condensate	回收冷凝水	●	●	●
Sodium Phosphate, Monobasic	磷酸鈉·磷酸二氫	●	●	●	Seawater	海水	●	●	●
Sodium Phosphate, Dibasic	磷酸鈉·磷酸氫二鈉	●	●	●	Tap Water	自來水	●	●	●
Sodium Phosphate, Tribasic	磷酸鈉·三鹽基	●	●	●	Whiskey and Wines	威士忌和葡萄酒	●	●	●
Sodium Silicate	矽酸鈉	●	●	●	Wood Alcohol	木醇	●	●	●
Sodium Sulfate	元明粉	●	●	●	Xylene	二甲苯	●	●	●
Sodium Sulfide	硫化鈉	●	●	●	Zinc Chloride	氯化鋅	●	●	●
Sodium Superoxide	超氧化鈉	●	●	●	Zinc Sulfate	硫酸鋅	●	●	●
Sodium Thiosulfate	硫代硫酸鈉	●	●	●					
Soybean Oil	豆油	●	●	●					
Stannic Chloride	氯化錫	●	●	●					
Steam, Saturated	飽和蒸汽	●	●	●					
Superheated	過熱	○	○	○					
Stearic Acid	硬脂酸	●	●	●					
Stoddard Soivent	乾洗油	●	●	●					
Styrene	苯乙烯	●	●	●					
Styrene Oxide	氧化苯乙烯	●	●	●					
Sugar	糖	○	○	○					
Sulfur Chloride	氯化硫	●	●	●					
Sulfur Dioxide	二氧化硫	●	●	●					
Sulfur, Molten	硫·熔融	●	●	●					
Sulfur Trioxide, Dry	三氧化硫·乾	●	●	●					
Sulfur Trioxide, Wet	三氧化硫·濕	●	●	●					
Sulfuric Acid, 10%, 70°C and below	硫酸·10%·小於等於70°C	●	●	●					
Sulfuric Acid, 10%, Above 70°C	硫酸·10%·大於70°C	●	●	●					
Sulfuric Acid, 10-75%, 260°C and below	硫酸·10-75%·小於等於260°C	●	●	●					
Sulfuric Acid, 75-98%, 70°C and below	硫酸·75-98%·小於等於70°C	●	●	●					
Sulfuric Acid, 75-98%, 70°C to 260°C	硫酸·75-98%·70°C~260°C	●	●	●					
Sulfuric Acid, Sulfuric Acid, Fuming	硫酸·硫酸·發煙	●	●	●					
Sulfurous Acid	亞硫酸	●	●	●					
Tannic Acid	鞣寧酸	●	●	●					
Tartaric Acid	酒石酸	●	●	●					
TCDB-p-Dioxin	戴奧辛	●	●	●					
Tertiary Butyl Amine	叔丁基胺	●	●	●					
Tetrabromoethane	四溴乙烷	●	●	●					
Tetrachlorethane	四氯乙烷	●	●	●					
Tetrachloroethylene	四氯乙烯	●	●	●					
Tetrahydrofuran, THF	四氫呋喃	●	●	●					
Thionyl Chloride	亞硫酸氯	●	●	●					
Titanium Sulfate	硫酸鈦	●	●	●					
Titanium Tetrachloride	四氯化鈦	●	●	●					
Toluene	甲苯	●	●	●					
Toluenediamine	甲苯二胺	●	●	●					
Toluenediisocyanate	甲苯二異氰酸	●	●	●					

四氟系列

膨體聚四氟板

EXPANDED PTFE SHEET

描述

是由 100%PTFE 的膨體聚四氟乙烯材料製成，獨特耐化學穩定性（不受一般化學品的影響），較低的摩擦係數，較廣闊的操作溫度，多纖維的結構使其作為密封產品具有超乎想像的堅韌性。其它四氟密封材料的通病 - 蠕變和冷流，與純四氟墊片和填充四氟墊片相比性能大為改善，另外，使用壽命長等特性使能在幾乎所有的密封場合中得到實際應用。

主要特點：

1. 適用於粗糙表面的密封膨體聚四氟乙烯墊片具有獨特順應成型能力，無需增加多少壓力就能在粗糙或受損的法蘭面上產生良好的密封效果。
2. 良好的抗化學腐蝕性能，幾乎可適用於任何化學流體。
3. 良好的抗蠕變性和耐高低溫性佳，獨特的高密度纖維結構，使其具有強烈的抗蠕變特性。由於不含任何黏合劑和添加劑，因而其機械性能十分穩定。

描述 Description	數據 Value	測試方法 Test Method
密度 Density(g/cm ³)	0.8	ASTM D792
拉伸強度 Tensile Strength. MPa	>15	ASTM F152
壓縮率 Compressibility(%)	>45	ASTM F36
恢復率 Recovery(%)	>10	
潛變鬆弛 (%) Creep relaxation(%)	<60	ASTN F38
溫度範圍 Temperature operating range(°C)	-240~260	
PH 值 PH value	0~14	
壓力範圍 Pressure range	真空 ~200bar	

板材供應厚度 (mm):

0.5、0.8、1.0、1.5、2.0、3.0、4.0、5.0

板材供應尺寸 (mm):

1500(W)*1500(L)、1500(W)*2000(L)、1500(W)*3000(L)

可依客戶需求訂製

四氟系列

膨體聚四氟 e-PTFE 密封帶 / 條 ePTFE Joint Sealant

e-PTFE(彈性膨體聚四氟乙烯) 帶是一種無機密封膠，是用 100% 純聚四氟乙烯製成。獨特加工製造成新，從而形成具有良好的柔韌性及良好的可壓縮性、回彈性、耐蠕變性、很高的抗拉強度，受壓後纖維相互纏結，變成組織更緊密而均勻！

適用：於密封法蘭連接，管道系統，液壓和氣動系統等。

主要特點：

- * 配有自粘條，便於方便，快速安裝。
- * 長期存放不變質，且無污染。
- * 減少廢料，其成本低於其他墊片材料。
- * 優越之填充順應性，可使用於粗糙或受損之法蘭。

技術數據

- * 介質：酸，鹼，溶劑，氣體等。
- * 溫度：-240 至 260°C
- * 壓力：200bar
- * 適用 PH 值：0~14

編號	寬度		厚度	長度
	英制	公制	mm	M
OL#703	1/8"	3	2	30
OL#705	3/16"	5	2	20
OL#706	1/4"	6	3	15
OL#709	3/8"	9.5	3	8
OL#730	1-1/4"	30	3	5
OL#750	2"	50	3	10
OL#713	3/16"	13	5	10
OL#730	1-1/4"	30	5	5
OL#7050	2"	50	5	10
OL#720	3/4"	20	7	5

可依需求提供其他寬度及厚度

橡膠系列

橡膠墊片

Rubber Sheet Gasket

橡膠是在中等溫度範圍（-50°C 至 +120°C）中用於密封的最重要的一類材料。這是因為遇到任何變形應力或載荷時，橡膠會迅速恢復其原始形狀。

可以用以下橡膠製造：

編號	材質	使用溫度範圍 硬度 ±5	特性 應用場合
OL#400	丁腈橡膠 NBR	-30°C ~120°C 70±5	耐油 / 耐磨 / 耐老化 / 耐酸鹼 水壓油、水 / 乙二醇及水感光乳劑中的油、有機 / 無機 / 植物的油、熱水、燃料、石油、稀釋酸 / 鹼及低溫鹽溶液、矽氧烷油、潤滑脂。
OL#500	乙丙烯橡膠 EPDM	-40°C ~150°C 70±5	耐氣候 / 耐蒸氣 / 耐酸鹼 蒸氣、熱水、稀釋酸、磷酸鹽脂為基礎的防火水壓流體及非礦物油為基礎的煞車油
OL#600	氯丁二烯 橡膠 CR	-30°C ~120°C 70±5	耐油 / 耐熱 / 耐臭氣 / 耐酸鹼 鹽水、通常用在冷媒（二氧二氟代甲烷 12）、二氧化碳、矽氧烷油及潤滑脂、阿摩尼亞
OL#700	矽橡膠 SI	-60°C ~230°C 50±5	耐氣候 / 耐寒 熱空氣、氧氣、水、機械及變速器的油、動 / 植物油及潤滑油、不含石油的煞車油、防火水壓流體、稀釋鹽溶液、臭氣
OL#800	氟橡膠 FKM (VITON)	-30°C ~200°C	耐油 / 耐熱 / 耐腐蝕 熱油、芳香溶劑、化學品、磷酸鹽酯為基礎的防火水壓流體、植物油及潤滑油、天然氣、燃料（含醇）、高真空、矽氧烷油及潤滑脂、臭氣

備註：本公司可提供其它相關橡膠材質之產品

橡膠系列

丁腈橡膠墊片 OL#400

NBR, Nitrile Butadiene Rubber

丁腈橡膠是一種合成橡膠，由丙烯腈與丁二烯單體聚合而成的共聚物，丙烯腈的含量愈高，耐潤滑油與耐燃料油特性就愈好，同時，低溫彈性則變差。相反的，當丙烯腈含量降低，耐低溫性就愈好，不過耐潤滑油與耐燃料油的性質就變差。

NBR 的標準使用溫度介於 -55°C 至 100°C 或達 125°C 。一般來說，溫度超過 100°C 時，其使用壽命會縮短。

NBR 具備絕佳的耐摩耗力，常用常用於密封件和墊片、O 型圈、密封墊圈、管件等。

適用於：水壓油、水 / 乙二醇及水感光乳劑中的油、有機 / 無機 / 植物的油、熱水、燃料、石油、稀釋酸 / 鹼及低溫鹽溶液、矽氧烷油、潤滑脂。

優點

耐油

耐磨性較高

氣密性好

耐熱性較好

黏接力強

耐老化性能較好

缺點

耐低溫性差

耐臭氧性差

絕緣性差

彈性稍低

不宜做絕緣材料

橡膠系列

乙丙烯橡膠墊片 OL#500 EPDM

常見名稱為乙丙烯橡膠、EPM、EPDM、乙丙烯橡膠等，為乙烯與丙烯共聚合，此橡膠原料名稱為 EPDM。最常見用於門框密封、車窗密封、行李箱密封、它還用作防水介質橡膠製品。也常用於散熱器、熱交換器、管材、襯墊、墊圈、電氣絕緣、抗震耐震、O 型圈、太陽能電池板集熱器和揚聲器墊材、車輛零件、建材、電線電纜，也因其耐化學性常用於膨脹接頭中等各種工業用橡膠製品。

EPDM 最主要的特性就是其優越的耐氧化、抗臭氣和抗侵蝕的能力。由於三元乙丙橡膠屬於聚烯烴家族，它具有極好的硫化特性。在所有橡膠當中，EPDM 具有最低的比重。它能吸收大量的填料和油而影響特性不大。因此可以製作成本低廉的橡膠化合物。

適用於：蒸氣、熱水、稀釋酸、磷酸鹽脂為基礎的防火水壓流體及非礦物油為基礎的煞車油

優點：

耐臭氣性非常優秀，優於 CR

耐候性佳，適用於戶外環境

耐熱性非常良好，可至 150°C 的高溫

電氣特性良好，耐電暈性

對極性溶劑（醇，酮），鹽酸等無機藥品很安定

與油，碳黑的混合性優秀，可高填充

缺點：

耐油，耐彎曲龜裂性差

未加硫生材粘著性不良

橡膠系列

氯丁二烯橡膠墊片 OL#600

CR, Chloroprene rubber

氯丁二烯橡膠是 1931 年由杜邦 (Dupont) 首次成功合成彈性體之一，商品名為氯丁橡膠。它是透過氯丁二烯或 2- 氯丁二烯的乳化聚合組成。CR 是多功能彈性體，整體物性表現都相當平衡。例如：它具有良好的耐日曬，耐臭氧，耐候性，並且耐油性及許多化學物甚佳。它還有出色的物理韌性和良好的耐燃性。

氯丁二烯橡膠展現出色的物理韌性與良好的耐燃性質並具備良好的耐臭氧、耐候性的特質，並且耐礦物油類及許多化學物甚佳、其耐油性佳，次於 NBR。但生膠儲存穩定性差，會產生自硫現象。

適用於：鹽水、通常用在冷媒 (二氧二氟代甲烷 12)、二氧化碳、矽氧烷油及潤滑脂、阿摩尼亞

優點：

具有優良的抗氧

抗臭氧性，不易燃，著火后能自熄

耐油、耐溶劑、耐酸鹼以及耐老化、氣密性好等優點

物理機械性能也比天然橡膠好，故可用作通用橡膠，也可用作特種橡膠

缺點：

耐寒性較差

比重較大、相對成本高

電絕緣性不好

加工時易粘滾、易焦燒及易粘模

橡膠系列

矽橡膠墊片 OL#700

SILICONE Rubber

SI 膠加強其彈性與使用壽命是很重要的，矽硅膠在極端的環境與溫度時表現很好，通常用於汽車與航空業。也具備出色的電絕緣屬性，這在應用於嚴格性能標準是不可或缺的。此外也常用於需要 FDA 認可的設備與裝置之食品級材料。高透光性矽膠的用途非常廣泛，可用於電子灌注封裝、醫療器材、機械零件防震、適用於電子烤箱密封條、塑膠帶封口機條、咖啡機食品管、飲水機電器絕緣管、烘乾機爐門條、矽膠導電異形條、矽膠管套、矽膠密封圈等。

矽膠配方具備絕佳的耐候性佳（抗 UV），耐化學性佳，防水性佳，電氣特性佳環保無毒，且其電解質穩定度很好，此外也具備耐潤滑油、耐化學性和耐溶劑的特質。在所有彈性體中，低溫時矽膠的彈性是最好的。不過矽膠也有一些缺點，如低拉伸強度，較差的耐撕裂、耐磨耗性且不耐燃料油。

適用於：熱空氣、氧氣、水、機械及變速器的油、動 / 植物油及潤滑油、不含石油的煞車油、防火水壓流體、稀釋鹽溶液、臭氧

優點：

防水性佳、耐化學性佳

高透光性、耐候性佳（抗 UV）

電氣特性佳、環保無毒

缺點：

低拉伸強度、不耐撕裂

不耐燃料油、不耐磨性

橡膠系列

氟橡膠墊片 OL#800 FKM(VITON)

FKM 尤其具備絕佳的耐高溫、耐臭氧、耐氣候、耐氧化、耐礦物油、耐燃料油、耐液壓油、耐芳香族與許多有機溶劑和化學物的性質常用於汽車業、化學製程、航太與許多工業上。

對於一般類型，在靜態時的標準使用溫度最好限於約 -26°C (-15°F) 至 232°C (450°F) 之間，雖然在溫度 275°C 短時間內仍可使用，但是溫度超過 232°C 時，其使用壽命會縮短。應用在動態時，最適合的溫度是介於 -15°C 至 200°C 。

適用於：熱油、芳香溶劑、化學品、磷酸鹽酯為基礎的防火水壓流體、植物油及潤滑油、天然氣、燃料（含醇）、高真空、矽氧烷油及潤滑脂、臭氧

優點

對於大部份油品及溶劑都具有抵抗的能力
耐芳香烴和氯化烴
可抗熱至 200°C
優良的耐酸性（無機酸）

缺點

熱拉伸及熱撕裂性差
熱水中高壓縮變形
不耐極性溶劑
延伸差、耐寒性差

橡膠系列

橡膠塗覆四氟墊片 OL#500-P PTFE Coated Rubber Gasket

四氟橡膠複合墊片採用高級 EPDM，在其有效密封部位複合經特殊活化處理的 100% 純 PTFE 外殼而成。產品減少了墊片冷流，增加了墊片的抗吹出性，使墊片具有良好剛性強度及壓縮、回彈、補償性，能滿足較高壓力及工況比較苛刻場合。

耐溫：-30~+150°C 最大壓力：20 BAR

特性

- 1、這種完美的墊片適用於鑄鐵、球墨鑄鐵、玻璃鋼等管路系統中，廣泛套用在鋼鐵、冶金、石油、化工、半導體、多晶矽、有機矽、化肥、染料、製藥、電力、環保污水處理等行業。
- 2、凸起的密封環，大大地減少了墊片和法蘭的密封接觸面，可保持較高的密封比壓，從而減少了 75% 為達到密封而在螺栓上外加的扭矩載荷。



橡膠系列

四氟包覆橡膠 O 型環

PTFE Encapsulated O-Ring

四氟包覆橡膠 O 型環是一種圓形密封件，其橫截面為圓形，由兩個組件組成，一個 PTFE 護套和芯材組成，賦予更強密封的功能。具有 FEP/PFA 的抗溶劑和耐化學性以及橡膠的柔韌性，用於需要耐化學性和衛生食品、製藥、化學、石化行業

護套和芯材組成，賦予更強密封的功能

FEP - 考慮整體耐腐蝕性、密封能力和溫度時最通用的。

PFA - 一種類似於 FEP 的碳氟共聚物，但它在升高的工作溫度下也提供了顯著改善的機械和蠕變性能

氟橡膠 - 黑色

一種結合了卓越的機械性能和抗壓縮永久變形的含氟彈性體化合物。這種特殊的增能器使 O 形環具有出色的記憶力和從變形中快速恢復的能力。

矽 - 紅色

這種彈性體具有與氟橡膠相似的機械性能，只是其抗壓縮永久變形能力略低。它更適用於較弱壓縮力密封的區域。

外層材質	內芯材質		耐溫範圍	最大壓力
FEP	VITON	OL#800-VF	-200°C ~205°C	50Bar
	SILICONE	OL#700-SF		
PFA	VITON	OL#800-VP	-200°C ~260°C	
	SILICONE	OL#700-SP		

耐油紙

耐油紙

TBA FIREFLY SHEET PACKING KERTAS GASKET PAPER

蔬菜纖維耐油接合墊片又稱耐油紙墊片或柴油紙墊片，色澤土黃色，不含石棉成分。廣泛用在一般汽車、機車工業的汽機油系統密合墊片材料。也是適合用於各類工業及工廠的潤滑油及溶劑系統之密合耐油墊片材料。最大耐溫 120 度，不適合做工業的密封墊片材料，具有高度柔韌性和壓縮性，容易加工裁切成型。

物理性質

最大耐熱溫度	120°C (250 °F)		
顏色	棕色		
壓縮率 (70 kg / cm ² , 1000psi) ASTM F36	25 - 40%		
恢復率 ASTM F36	40 % min.		
抗拉強度 ASTM F152	13.79 MN/m ² min.		
抗流體特性：經過 22 小時攝氏 21~30 度 (華氏 70~85 度) 之測試			
耐油性能	ASTM IRM 903 油 ASTM F146	重量增加率	15% max.
		厚度增加率	5 % max.
	ASTM 燃料油 B ASTM F146	重量增加率	15 % max.
		厚度增加率	5 % max.
	蒸餾水 ASTM F146	重量增加率	90% max.
		厚度增加率	30% max.

軟木橡膠墊片

軟木橡膠墊片

Cork Rubber Sheet Gasket

軟木可用作天然軟木、樹脂粘合軟木和橡膠粘合軟木，橡膠粘合軟木用於墊圈。根據用於製造材料的顆粒大小和與材料粘合的基礎橡膠化合物（通常是氯丁橡膠或丁腈橡膠）而有所不同。軟木材料以其用於密封酒瓶而聞名，可製成相對便宜且有效的密封件，並具有良好的耐油性。由於這些特性，軟木墊片通常用於：油底殼、曲軸箱蓋、檢查門、閥蓋、電氣變壓器墊片、通用蓋和蓋子、電氣開關設備和防震用途。

丁腈軟木塞
一般特性：

- 具有良好的耐油性
- 具有良好的耐溶劑性
- 相對便宜
- 在低法蘭壓力下密封良好
- 在高達 120°C 的溫度下密封良好
- 適合與汽油一起使用
- 適用於螺栓加載法蘭
- 適用於劣質法蘭

盤根

編織盤根 Braided Gland Packing

編號	品名	使用溫度範圍		最大使用壓力 bar
		最低°C	最高°C	
OL#100	石棉浸漬四氟盤根	-50	260	300
OL#200	擰麻纖維浸四氟浸油盤根	-50	130	100
OL#210	四氟盤根	-200	280	150
OL#220	含油四氟盤根	-200	280	150
OL#230	四角芳綸增強四氟盤根	-100	280	200
OL#240	四氟纖維盤根	-200	280	250
OL#250	石墨四氟盤根	-200	280	200
OL#260	四角芳綸增強石墨四氟盤根	-100	280	250
OL#270	芳綸纖維浸漬四氟盤根	-100	280	250

盤根

編織盤根

編號	品名	使用溫度範圍		最大使用壓力 bar
		最低°C	最高°C	
OL#280	碳化纖維浸漬四氟盤根	-50	260	150
OL#300	柔性石墨編織盤根	-250	650	250
OL#310	玻璃纖維加鎳鉻絲增強石墨盤根	-250	650	250
OL#320	外編鎳鉻絲棉織增強石墨盤根	-250	650	500
OL#330	鎳鉻絲增強石墨盤根	-250	650	300
OL#340	四角加碳玻璃纖維增強石墨盤根	-250	650	400



API 622 PACKING GR8622

Composition

Pure expanded mineral graphite
Reinforcement in nickel-alloy and impregnation with special graphite-based compounds.

Characteristics

The graphite seal ring gasket for valves GR8622 is characterized by the use of pure expanded mineral graphite, which ensures high sealing performance. Thanks to its Low Emission API std 622 3rd Edition certification, this packing is particularly suitable for applications where low gas emissions into the environment are required. The GR8622 is able to maintain its elastic properties and sealing performance over time, without the need for re-tightening. The yarn used offers very low weight loss during high-temperature operation and a low coefficient of friction, making it suitable for applications that require high slipperiness. In addition, the GR8622 gasket is able to withstand high pressures and extreme temperatures, ensuring reliable and long-lasting sealing.

Applications

GR8622 is a specially designed packing for industrial valves used in low emissions service, also suitable for those with H.P./H.T. service. Made of pure expanded mineral graphite, this graphite packing ring for valve sealing is certified Low Emission API std 622 3rd Edition and maintains its elastic properties and sealing performance over time without the need for re-tightening. Additionally, the yarn provides a very low weight loss at high temperatures and offers a low coefficient of friction, ensuring high performance and reliability in industrial use.

Tech Data

	P bar	lbf/in2	Vm/S	f/pm	pH	T°C	T°F
	500	7250	2	400	0 ÷ 14	-200 ÷ 450 / 650	-240 ÷ 850 / 1200

- Never use the product to the maximum temperature and pressure associated. Consult the manufacturer for further information
- The peak temperature can be sustained for short exposures
- With weakly oxidizing agents and hot air the temperature must be limited to 450 °C
- With steam and non-oxidizing fluids the temperature must be limited to 650 °C
- Graphite and carbon cannot be used with oxidizing fluids

Approvals

API 622 2nd Edition

Fire Test API 589

Corrosion Test

Weight Loss Test EN 14772, section 6.7



API 622 Packing GR8622

The Carrara graphite gland packing product range includes items made with all available graphite yarns, which, according to ASTM F2191 classification, are Type I—Continuous yarn, Type II—Staple yarn, and Type III—Flexible yarn. All graphite gland packings are protected with passive or active corrosion inhibitors (Grade A—Treated with corrosion inhibitor), although untreated gland packings (Grade B—No corrosion inhibitor) are available on demand. The performer and premium grade product ranges include Class 2 items, while the Industrial grade product range offers Class 1 products. Carrara graphite gland packings are specialized for each application, and a proper selection of the item allows for maximizing the sealing performance while reducing the component management costs.



The information in this publication and otherwise provided to users is based on experience and is provided to the best of our current knowledge. Due to many factors which are beyond our knowledge and control affecting the use of the products, no warranties are given or are to be held implied with respect to such information. The operating limits shown in this publication do not constitute a statement that these values can be applied simultaneously. Do not use the product at the associated maximum temperature and pressure values. The maximum temperature can be sustained for short exposures in particular conditions. Specifications are subject to change without notice.



Carrara S.p.A.
Via Provinciale 1/E - 25030 Adro - BS - Italia
tel. +39 030 7451121 / fax +39 030 7451130
www.carrara.it - info@carrara.it

防火保溫系列

耐溫防火材（陶瓷纖維）

各類耐溫防火編織布用途十分廣泛，適用於各種風管膨脹接頭、機械、模具隔熱罩、高溫場所隔熱簾、消防衣及各式隔熱護具。編織帶適用於熱輸送管路之保溫、烤箱爐門迫緊、法蘭迫緊、鍋爐墊片、不平坦之高溫隙縫及機械構造物內空隙項塞。編織繩適用於密封高溫爐內或高壓氣流體空隙、烤箱門縫填塞用。

名稱	使用溫度℃
陶瓷纖維布	1260
陶瓷纖維帶	1260
陶瓷纖維繩	1260

耐溫防火材（玻璃纖維）

名稱	使用溫度℃
玻璃纖維布	593
玻璃纖維帶	593
玻璃纖維繩	593

雲母系列

型號		FMI-HIGH®	MICATHERM® S15
組成		雲母 + 不溶性纖維 SS316L	雲母 + 特殊樹脂 SS316L
密度 (g/cm ³) DIN 28090-2		1.6~1.9	1.65~1.95
最高作業溫度 (°C)		950	900
最高作業工作壓力 (Bar)		200	60
洩漏率 (mg*s-1*m-1) DIN 3535-6		< 0.1	< 0.1
潛變鬆弛 (%) DIN 3535-6		< 18	< 12
壓縮率 (%) DIN 3535-6		> 20	> 16
復原率 (%) DIN 3535-6		> 2.2	> 3
尺寸規格	長度 * 寬度 (mm)	1500*1500	1500*1500
	厚度 (mm)	1000*1000 1~3	1000*1000 1~3
公差	長度 * 寬度 (mm)	+/- 50	+/- 50
	厚度 (%)	+/- 10	+/- 10

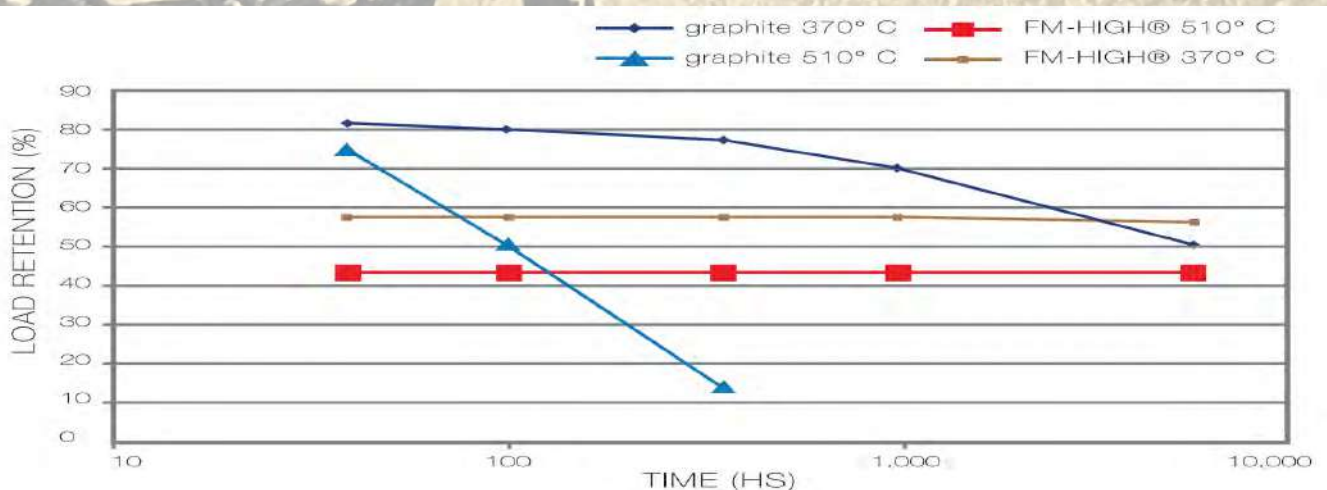
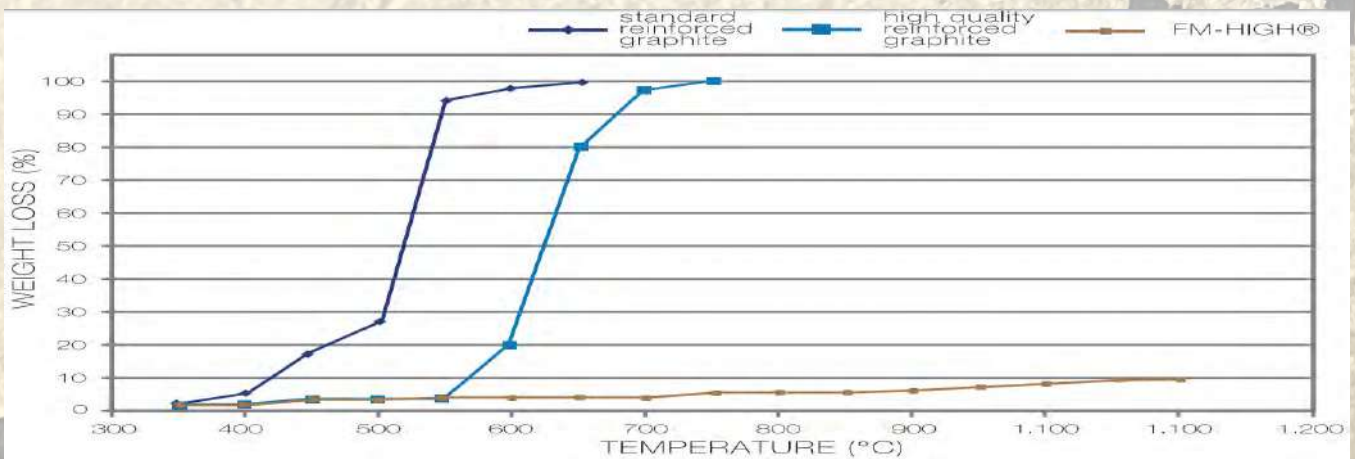

雲母系列

FMI-HIGH®

防火 API 6FB 認證

是由含有生物溶解性纖維的雲母結合 SS316 鋼芯而成的高性能密封材料，專用於溫度不斷升高的工作環境及應用在強氧化性介質壓力的場合。

顏色 金

工作溫度 950°C

最高溫度 1100°C

最大壓力 200Bar

pH 值範圍 0~14

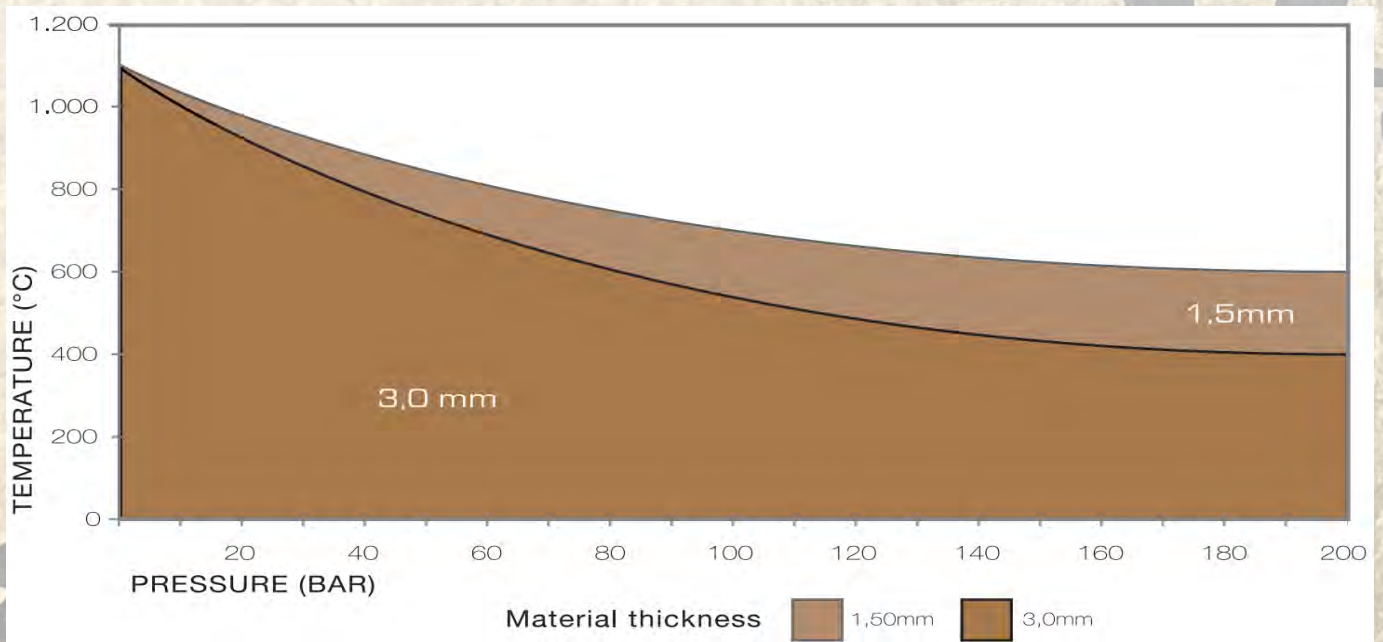

雲母系列

MICATHERM® S15



防火 API 6FB 認證

是由含有特殊樹脂的雲母結合 SS316 鋼芯而成的高性能密封材料。應用在專於高溫工作環境。

顏色 金棕

最高溫度 900°C

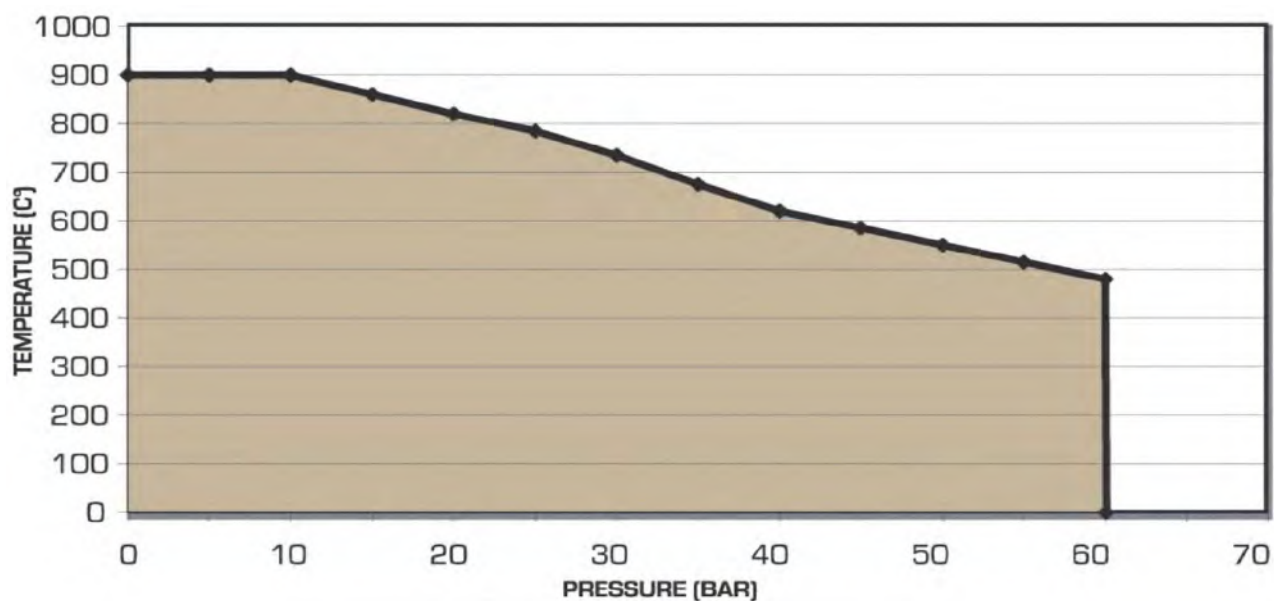
最大壓力 60Bar



英文名稱	中文名稱	FM-HIGH	S15	英文名稱	中文名稱	FM-HIGH	S15
Carbon monoxide	一氧化碳	●		Mineral oil	礦物油	●	
Carbon tetrachloride	四氯化碳	●		Mobiltherm	美孚熱煤油	●	
Chile saltpetre	智利鹽石	●		Naphthalene	萘	●	
Chlorine, dry	氯·乾	●		Natural gas	天然氣	●	
Chlorine, wet	氯·濕	●		Nitric acid (concentrated 50%)	硝酸(濃縮50%)	●	
Chlorinated hydrocarbons	氯化碳氫化合物	●		Nitric acid (fuming 95%)	硝酸(發煙95%)	●	
Chloroacetic acid	氯乙酸	●		Nitrogen	氮	●	
Chloro benzene	氯苯	●		Oleum	發煙硫酸	●	
Chromic acid	鉻酸	●		Oxygen	氧	●	
Copper sulphate	硫酸銅	●		Paraffin	石蠟	●	
Creosote	雜酚油	●		Pentachlorophenol	五氯酚	●	
Cresol	甲酚	●		Perchloric acid	高氯酸	●	
Crude oil	原油	●		Petroleum	石油	●	
Cyclohexanol	環己醇	●		Phenol	苯酚	●	
Dichlorobenzene	二氯苯	●		Phosgene	光氣	●	
Dye Liquor	染色酒	●		Phosphoric acid (concentrated)	磷酸(濃縮)	●	
Ethyl acetate	乙酸乙酯	●		Phosphoric acid (dilute)	磷酸(稀)	●	
Ethyl alcohol	乙醇	●		Phosphorous	磷	●	
Ethylene glycol	乙二醇	●		Phthalic anhydride	鄰苯二甲酸酐	●	
Ethylene oxide	環氧乙烷	●		Potassium hydroxide	氫氧化鉀	●	
Ethyl ether	乙醚	●		Potassium nitrate	硝酸鉀	●	
Ethylene	乙烯	●		Potassium permanganate	高錳酸鉀	●	
Ethylene chloride	氯化乙烯	●		Producer gas	生產氣體	●	
Fatty acids	脂肪酸	●		Pyridine	吡啶	●	
Ferric chloride	氯化鐵	●		Sea water	海水	●	
Fluorine	氟	●		Silicone oil	矽油	●	
Fluorosilicic acid	氟矽酸	●		Soda ash	蘇打粉	●	
Formaldehyde	甲醛	●		Sodium bi-carbonate	二碳酸鈉	●	
Formic acid 85%	甲酸85%	●		Sodium carbonate	碳酸鈉	●	
Formic acid 10%	甲酸10%	●		Sodium cyanide	氰化鈉	●	
Freons	冷煤	●		Sodium hydroxide (40%)	氫氧化鈉(40%)	●	
Gas oil	瓦斯油	●		Sodium hydroxide (dilute)	氫氧化鈉(稀)	●	
Gasoline	汽油	●		Sodium hypochlorite	次氯酸鈉	●	
Heating oil	加熱油	●		Sodium nitrate	硝酸鈉	●	
Hydraulic oil (glycol)	液壓油(乙二醇)	●		Starch	澱粉	●	
Hydraulic oil (mineral)	液壓油(礦物)	●		Steam	蒸汽	●	
Hydraulic oil (phosphate ester)	液壓油(磷酸酯)	●		Steam condensate	蒸汽冷凝水	●	
Hydrazine	肼	●		Styrene	苯乙烯	●	
Hydrocarbons (aromatic)	碳氫化合物(芳香族)	●		Sulphur	硫	●	
Hydrocarbons aliphatic (sat.)	脂肪族(飽和)	●		Sulphur dioxide	二氧化硫	●	
Hydrocarbons aliphatic (unsat.)	脂肪族(不飽和)	●		Sulphur trioxide	三氧化硫	●	
Hydrochloric acid (37% HCl)	氫氯酸(37% HCl)	●		Sulphuric acid (concentrated)	硫酸(濃縮)	●	
Hydrofluoric acid	氫氟酸	●		Sulphuric acid (fuming)	硫酸(發煙)	●	
Hydrogen	氫	●		Tar	柏油	●	
Hydrogen chloride	氯化氫	●		Turpentine	松節油	●	
Hydrogen fluoride	氟化氫	●		Toluene	甲苯	●	
Hydrogen peroxide	過氧化氫	●		Towns gas	城鎮氣	●	
Hydrogen sulfide	硫化氫	●		Transformer oil	變壓器油	●	
Isopropyl acetate	異丙酸異丙酯	●		Tributyl phosphate	磷酸三丁酯	●	
Isopropyl alcohol	異丙醇	●		Triethanolamine	三乙醇胺	●	
Kerosene	煤油	●		Urea	尿素	●	
Lime	青檸	●		Vegetable Oil	植物油	●	
Lubrication oil	潤滑油	●		Vinyl acetate	醋酸乙烯酯	●	
Machine oil	機油	●		Vinyl chloride	氯乙烯	●	
Magnesium sulphate	硫酸鎂	●		Vinylidene chloride	偏二氯乙烯	●	
Malic acid	蘋果酸	●		Water	水	●	
Methane	甲烷	●		Water conolenstate	水壺	●	
Methyl acrylate	丙烯酸甲酯	●		Water distilled	水蒸餾	●	
Methyl alcohol	甲醇	●		Whisky	威士忌酒	●	
Methyl isobutyl ketone	甲基異丁基酮	●		Wine	紅酒	●	
Methyl methacrylate	甲基丙烯酸甲酯	●		White Spirit	白酒	●	
Methylene chloride	二氯甲烷	●		Xylene	二甲苯	●	

絕緣系列

絕緣組

Insulation Gasket Kits

絕緣墊片材質

名稱	等級	吸水性 %	抗拉強度 PSI	壓縮強度 PSI	彎曲強度 PSI	介電強度 VPM	最大連續 操作溫度
電木 (布質) Canvas Based Phenolic	CE	3.5	11000	34000	17500	400	257 °F (125°C)
電木 (紙質) Phenolic & Paper Laminate	XP	1.5	18000	45000	29000	600	266 °F (130°C)
橡膠塗覆電木 Neoprene/NBR Faced Phenolic & Paper Laminate	XPN	1.5	18000	45000	29000	600	266 °F (130°C)
玻纖強化環氧樹脂 Glass Fiber Reinforced Epoxy	FR4/ G10	0.05	50000	66000	65000	800	302 °F (150°C)
玻纖強化環氧樹脂 Glass Fiber Reinforced Epoxy	FR5/ G11	0.085	43000	63000	80000	900	390 °F (200°C)
玻纖強化矽橡膠 Glass Fiber Reinforced Silicone	G7	0.19	25000	40000	18500	350	428 °F (220°C)
玻纖強化酚醛樹脂 Glass Fiber Reinforced Phenolic Resin	G3	2.0	42000	76000	55000	375	617 °F (325°C)

絕緣管套及華司材質

名稱	等級	吸水性 %	介電強度 VPM	最大連續 操作溫度
聚乙烯 Polyethylene	-	0.1	450	105 °F (41°C)
電木 Mycarta Phenolic	LE	1.1	400-500	225 °F (107°C)
玻纖強化環氧樹脂 Glass Fiber Reinforced Epoxy	FR4/ G10	0.05	800	302 °F (150°C)
聚脂薄膜 Polyester Film	Mylar	0.8	4000	300 °F (149°C)
方綸纖維 meta-aramid fiber	Nomex	-	400	450 °F (232°C)

絕緣系列

絕緣組

Insulation Gasket Kits

法蘭絕緣套件通常用於需要電化腐蝕防護和電氣絕緣的離岸設施、海水環境、化學設施、煉油廠管道。用於電氣法蘭絕緣。它們做為不同金屬法蘭之間的絕緣體，或用於電氣隔離陰極保護系統中的管道部分，防止靜電荷沿著管道流動。

套件內容

我們提供三種標準類型的法蘭絕緣套件；設計用於凸面、平面或環槽法蘭組件。

Type F - Inner Bolt Circle (IBC) Gasket

內部螺栓圈絕緣套件採用位於螺栓內的中央墊圈。墊圈的外徑緊密貼合到位，確保居中位置。該圖清楚地顯示了相對的法蘭如何完全絕緣。適用於全平面和突面法蘭。

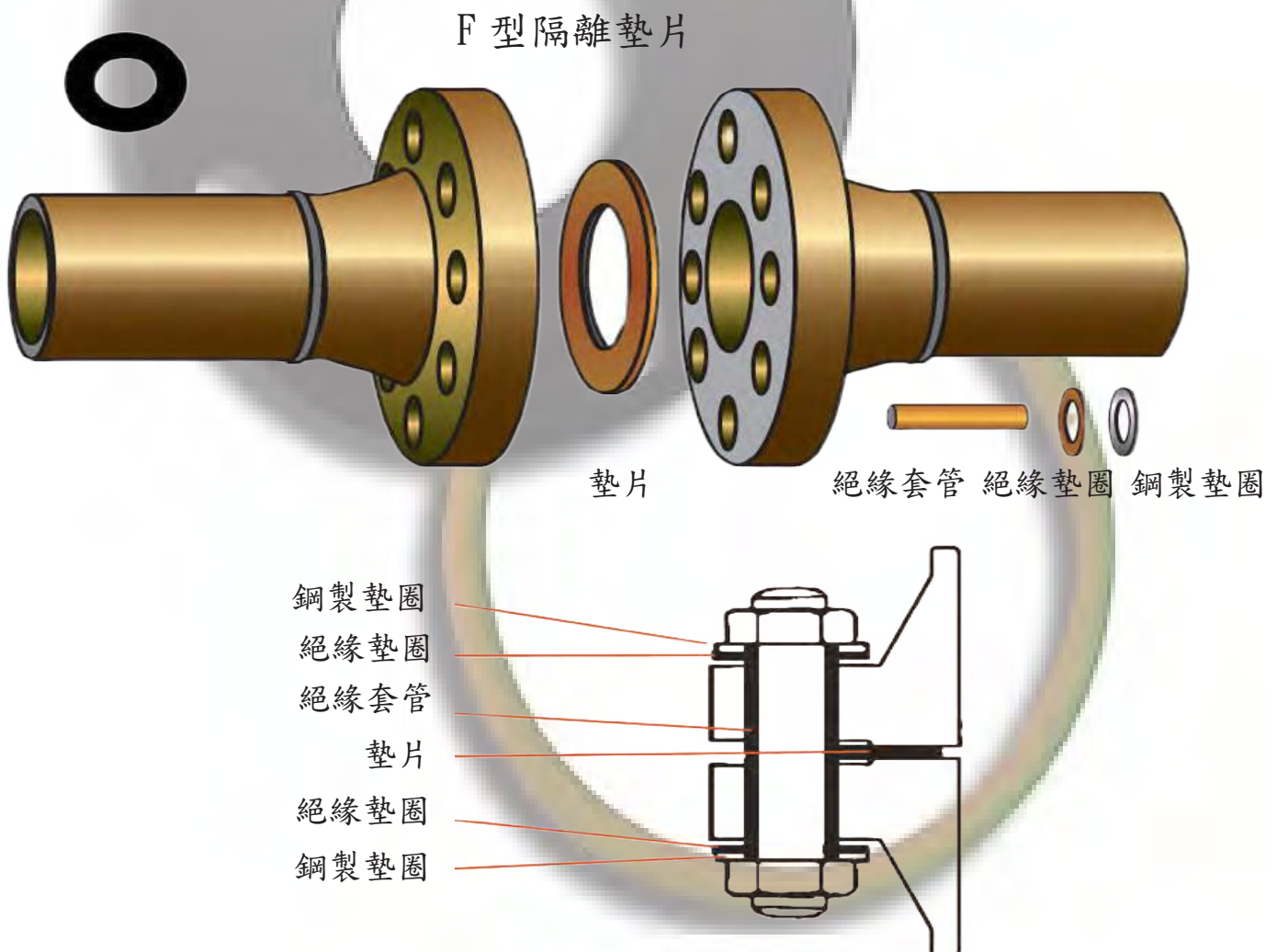

絕緣系列

絕緣組

Type E - Full Face

全面絕緣套件適用於平面和凸面法蘭。此組件大幅減少導電異物進入法蘭的情況，並降低了銜接的風險。該圖清楚地顯示了相對的法蘭如何完全絕緣。適用於全平面和突面法蘭。

E 型隔離墊片

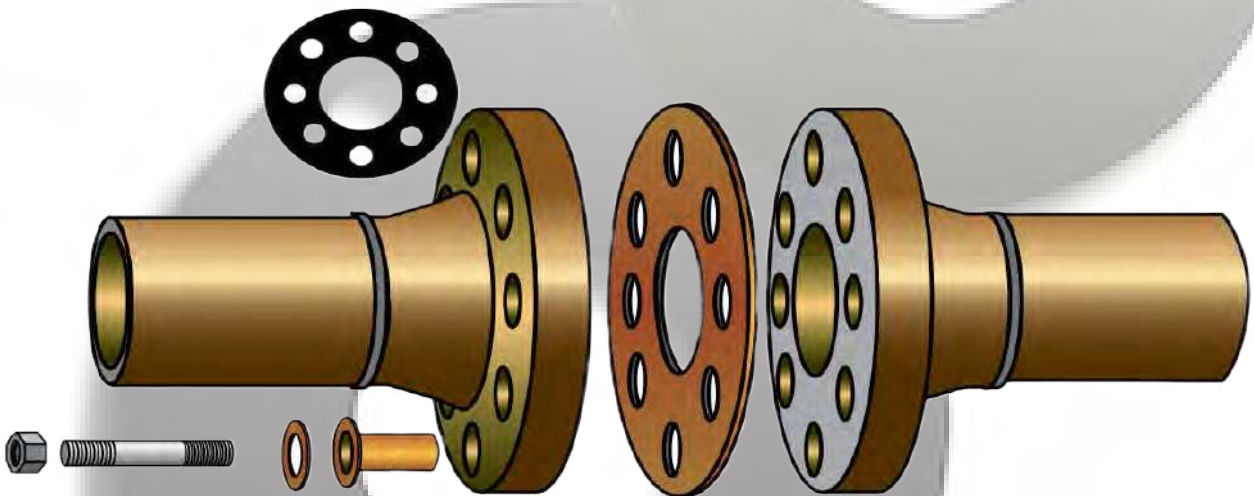

螺帽 雙頭螺柱 絕緣墊圈 一件絕緣套管和墊片

鋼製墊圈

絕緣墊圈

絕緣套管

墊片

絕緣墊圈

鋼製墊圈

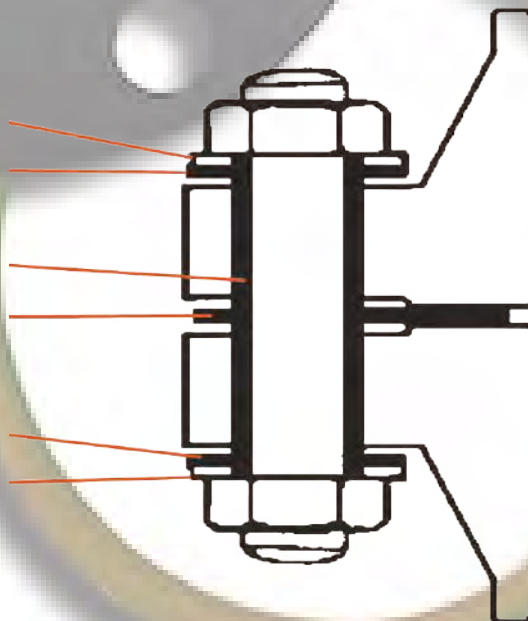

絕緣系列

絕緣組

Type D-RTJ

環形接頭絕緣套件由橢圓形絕緣環形接頭墊片組成，適用於標準 RTJ 法蘭。該圖清楚地顯示了相對的法蘭如何完全絕緣。適用於標準環形接頭法蘭。

D 型隔離墊片

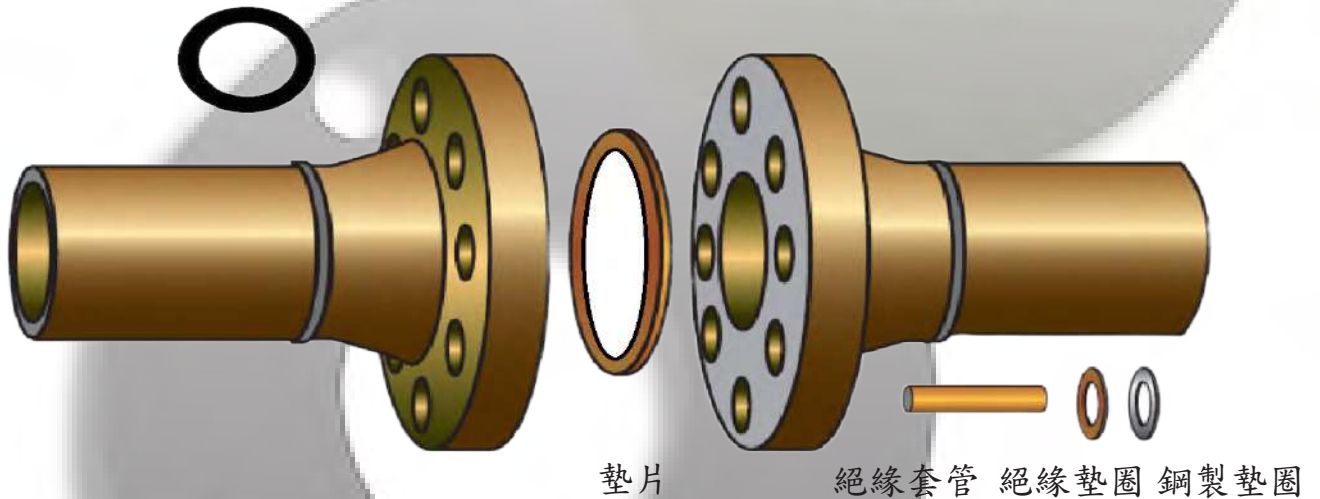

鋼製墊圈

絕緣墊圈

絕緣套管

墊片

絕緣墊圈

鋼製墊圈

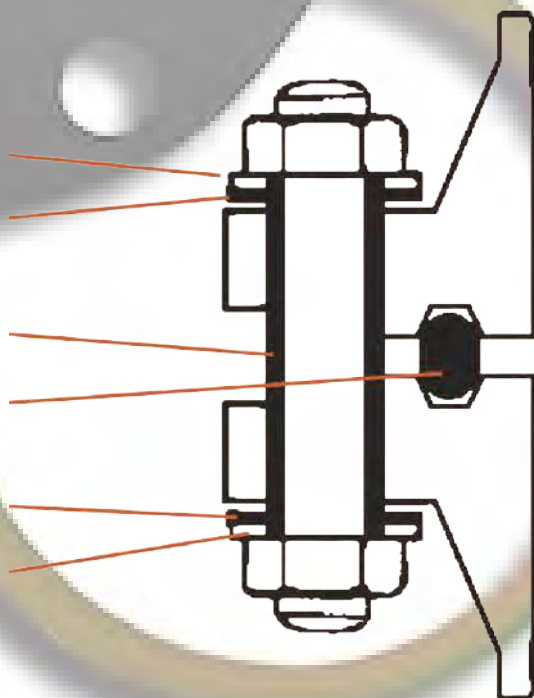

絕緣組尺寸表

			GASKETS					BOLTS			SLEEVES				WASHERS			
Nominal Pipe Diameter	Gasket Inside Diameter	Class Rating LBS	Outside Dia. Type E (inches)	Outside Dia. Type E (mm)	Outside Dia. Type F (inches)	Outside Dia. Type F (mm)	Ring No. Type D	Number of Bolts	Size of Bolts (inches)	Size of Bolts (mm)	Inside Dia. (inches)	Inside Dia. (mm)	Length (inches)	Length (mm)	Inside Dia. (inches)	Inside Dia. (mm)	Outside Dia. (inches)	Outside Dia. (mm)
1/2 15mm	1/2 15mm	150 300 4/600	3.1/2	88.90	1.11/16	42.86	-	4	1/2	12.70	1/2	12.70	1.1/16	26.99	9/16	14.29	1.1/8	28.58
			3.3/4	95.25	1.15/16	49.21	R11	4	1/2	12.70	1/2	12.70	1.5/16	33.34	9/16	14.29	1.1/8	28.58
			3.3/4	95.25	1.15/16	49.21	R11	4	1/2	12.70	1/2	12.70	1.13/16	46.04	9/16	14.29	1.1/8	28.58
			4.3/4	120.65	2.5/16	58.74	R12	4	3/4	19.05	3/4	19.05	2.7/16	61.91	13/16	20.64	1.9/16	39.69
			5.1/4	133.35	2.9/16	65.09	R13	4	3/4	19.05	3/4	19.05	3.1/16	77.79	13/16	20.64	1.9/16	39.69
3/4 20mm	3/4 20mm		3.7/8	98.43	2.1/16	52.39	-	4	1/2	12.70	1/2	12.70	1.3/16	30.16	9/16	14.29	1.1/8	28.58
			4.5/8	117.48	2.7/16	61.91	R13	4	5/8	15.88	5/8	15.88	1.7/16	36.51	11/16	17.46	1.5/16	33.34
			4.5/8	117.48	2.7/16	61.91	R13	4	5/8	15.88	5/8	15.88	1.15/16	49.21	11/16	17.46	1.5/16	33.34
			5.1/8	130.18	2.9/16	85.09	R14	4	3/4	19.05	3/4	19.05	2.11/16	68.26	13/16	20.64	1.9/16	39.69
			5.1/2	139.70	2.13/16	71.44	R16	4	3/4	19.05	3/4	19.05	3.3/16	80.96	13/16	20.64	1.9/16	39.69
1 25mm	1 25mm		4.1/4	107.95	2.7/16	61.91	R15	4	1/2	12.70	1/2	12.70	1.5/16	33.34	9/16	14.29	1.1/8	28.58
			4.7/8	123.83	2.11/16	68.26	R16	4	5/8	15.88	5/8	15.88	1.9/16	39.69	11/16	17.46	1.5/16	33.34
			4.7/8	123.83	2.11/16	68.26	R16	4	5/8	15.88	5/8	15.88	2.1/16	52.39	11/16	17.46	1.5/16	33.34
			5.7/8	149.23	2.15/16	74.61	R16	4	7/8	22.23	7/8	22.23	2.13/16	71.44	15/16	23.81	1.3/4	44.45
			6.1/4	158.75	3.3/16	80.96	R18	4	7/8	22.23	7/8	22.23	3.7/16	87.31	15/16	23.81	1.3/4	44.45
1.1/4 32mm	1.1/4 32mm		4.5/8	117.48	2.13/16	71.44	R17	4	1/2	12.70	1/2	12.70	1.7/16	36.51	9/16	14.29	1.1/8	28.58
			5.1/4	133.35	3.1/16	77.79	R18	4	5/8	15.88	5/8	15.88	1.11/16	42.86	11/16	17.46	1.5/16	33.34
			5.1/4	133.35	3.1/16	77.79	R18	4	5/8	15.88	5/8	15.88	2.5/16	58.74	11/16	17.46	1.5/16	33.34
			6.1/4	158.75	3.5/16	84.14	R18	4	7/8	22.23	7/8	22.23	2.15/16	74.61	15/16	23.81	1.3/4	44.45
			7.1/4	184.15	3.15/16	100.01	R21	4	1	25.40	1	25.40	3.11/16	93.66	1.1/16	26.99	2	50.80
1.1/2 40mm	1.1/2 40mm		5	127.00	3.3/16	80.96	R19	4	1/2	12.70	1/2	12.70	1.9/16	39.69	9/16	14.29	1.1/8	28.58
			6.1/8	155.58	3.9/16	90.49	R20	4	3/4	19.05	3/4	19.05	1.13/16	46.04	13/16	20.64	1.9/16	39.69
			6.1/8	155.58	3.9/16	90.49	R20	4	3/4	19.05	3/4	19.05	2.7/16	61.91	13/16	20.64	1.9/16	39.69
			7	177.80	3.11/16	93.66	R20	4	1	25.40	1	25.40	3.3/16	80.96	1.1/16	26.99	2	50.80
			8	203.20	4.7/16	112.71	R23	4	1.1/8	28.58	1.1/8	28.58	4.3/16	106.36	1.3/16	30.16	2.3/16	55.56
2 50mm	2 50mm		6	152.40	3.15/16	100.01	R22	4	5/8	15.88	5/8	15.88	1.11/16	42.86	11/16	17.46	1.5/16	33.34
			6.1/2	165.10	4.3/16	106.36	R23	8	5/8	15.88	5/8	15.88	1.15/16	49.21	11/16	17.46	1.5/16	33.34
			6.1/2	165.10	4.3/16	106.36	R23	8	5/8	15.88	5/8	15.88	2.11/16	68.26	11/16	17.46	1.5/16	33.34
			8.1/2	215.90	5.7/16	138.11	R24	8	7/8	22.23	7/8	22.23	3.11/16	93.66	15/16	23.81	1.3/4	44.45
			9.1/4	234.95	5.9/16	141.29	R26	8	1	25.40	1	25.40	4.11/16	119.06	1.1/16	26.99	2	50.80
2.1/2 65mm	2.1/2 65mm		7	177.80	4.11/16	119.06	R25	4	5/8	15.88	5/8	15.88	1.15/16	49.21	11/16	17.46	1.5/16	33.34
			7.1/2	190.50	4.15/16	125.41	R26	8	3/4	19.05	3/4	19.05	2.3/16	55.56	13/16	20.64	1.9/16	39.69
			7.1/2	190.50	4.15/16	125.41	R26	8	3/4	19.05	3/4	19.05	2.15/16	74.61	13/16	20.64	1.9/16	39.69
			9.5/8	244.48	6.5/16	160.34	R27	8	1	25.40	1	25.40	3.15/16	100.01	1.1/16	26.99	2	50.80
			10.1/2	266.70	6.7/16	163.51	R28	8	1.1/8	28.58	1.1/8	28.58	5.3/16	131.76	1.3/16	30.16	2.3/16	55.56
3 80mm	3 80mm		7.1/2	190.50	5.3/16	131.76	R29	4	5/8	15.88	5/8	15.88	2.1/16	52.39	11/16	17.46	1.5/16	33.34
			8.1/4	209.55	5.11/16	144.46	R31	8	3/4	19.05	3/4	19.05	2.7/16	61.91	13/16	20.64	1.9/16	39.69
			8.1/4	209.55	5.11/16	144.46	R32	8	3/4	19.05	3/4	19.05	3.3/16	80.96	13/16	20.64	1.9/16	39.69
			9.1/2	241.30	6.7/16	163.51	R31	8	7/8	22.23	7/8	22.23	3.11/16	93.66	15/16	23.81	1.3/4	44.45
			10.1/2	266.70	6.11/16	169.86	R35	8	1.1/8	28.58	1.1/8	28.58	4.7/16	112.71	1.3/16	30.16	2.3/16	55.56
3.1/2 90mm	3.1/2 90mm		12	304.80	7.9/16	192.09	R32	8	1.1/4	31.75	1.1/4	31.75	5.15/16	150.81	1.5/16	33.34	2.7/16	73.03
			8.1/2	215.90	6.3/16	157.16	R33	8	5/8	15.88	5/8	15.88	2.1/16	52.39	11/16	17.46	1.5/16	33.34
			9	228.60	6.5/16	160.34	R34	8	3/4	19.05	3/4	19.05	2.9/16	65.09	13/16	20.64	1.5/16	33.34
			9	228.60	6.3/16	157.16	R34	8	7/8	22.23	7/8	22.23	3.1/16	77.79	15/16	23.81	1.3/4	44.45
			9	228.60	6.11/16	169.86	R36	8	5/8	15.88	5/8	15.88	2.1/16	52.39	11/16	17.46	1.5/16	33.34
4 100mm	4 100mm		10	254.00	6.15/16	176.21	R37	8	3/4	19.05	3/4	19.05	2.11/16	68.26	13/16	20.64	1.9/16	39.69
			10	254.00	6.15/16	176.21	R37	8	7/8	22.23	7/8	22.23	3.7/16	87.31	15/16	23.81	1.3/4	44.45
			10.3/4	273.05	7.7/16	188.91	R37	8	7/8	22.23	7/8	22.23	3.11/16	93.66	15/16	23.81	1.3/4	44.45
			11.1/2	292.10	7.15/16	201.61	R37	8	1.1/8	28.58	1.1/8	28.58	4.13/16	122.24	1.3/16	30.16	2.3/16	55.56
			12.1/4	311.15	8.1/16	204.79	R39	8	1.1/4	31.75	1.1/4	31.75	4.15/16	125.41	1.5/16	33.34	2.7/16	61.91
5 125mm	5 125mm		14	355.60	9.1/16	230.19	R38	8	1.1/2	38.10	1.1/2	38.10	6.11/16	169.86	1.9/16	39.69	2.7/8	73.03
			10	254.00	7.9/16	192.09	R40	8	3/4	19.05	3/4	19.05	2.1/16	52.39	13/16	20.64	1.9/16	39.69
			11	279.40	8.5/16	211.14	R41	8	3/4	19.05	3/4	19.05	2.15/16	74.61	13/16	20.64	1.9/16	39.69
			11	279.40	8.1/16	204.79	R41	8	7/8	22.23	7/8	22.23	3.11/16	93.66	15/16	23.81	1.3/4	44.45
			11	279.40	9.5/16	236.54	R41	8	1	25.40	1	25.40	4.3/16	106.36	1.1/16	26.99	2	50.80
5 125mm	5 125mm		13.3/4	349.25	9.9/16	242.89	R41	8	1.1/4	31.75	1.1/4	31.75	4.11/16	119.06	1.5/16	33.34	2.7/16	61.91
			14.3/4	374.65	9.13/16	249.24	R44	8	1.1/2	38.10	1.1/2	38.10	6.7/16	163.51	1.9/16	39.69	2.7/8	73.03
			16.1/2	419.10	10.13/16	274.64	R42	8	1.3/4	44.45	1.3/4	44.45	7.15/16	201.61	1.13/16	46.04	3.5/16	84.14

絕緣組尺寸表

			GASKETS					BOLTS			SLEEVES				WASHERS			
Nominal Pipe Diameter	Gasket Inside Diameter	Class Rating LBS	Outside Dia. Type E (inches)	Outside Dia. Type E (mm)	Outside Dia. Type F (inches)	Outside Dia. Type F (mm)	Ring No. Type D	Number of Bolts	Size of Bolts (inches)	Size of Bolts (mm)	Inside Dia. (inches)	Inside Dia. (mm)	Length (inches)	Length (mm)	Inside Dia. (inches)	Inside Dia. (mm)	Outside Dia. (inches)	Outside Dia. (mm)
6 150mm	6 150mm	150	11	279.40	8.9/16	217.49	R43	8	3/4	19.05	3/4	19.05	2.3/16	55.56	13/16	20.64	1.9/16	39.69
		300	12.1/2	317.50	9.11/16	246.06	R45	12	3/4	19.05	3/4	19.05	3.1/16	77.79	13/16	20.64	1.9/16	39.69
		400	12.1/2	317.50	9.9/16	242.89	R45	12	7/8	22.23	7/8	22.23	3.5/16	84.14	15/16	23.81	1.3/4	44.45
		600	14	355.60	10.5/16	261.94	R45	12	1	25.40	1	25.40	4.7/16	112.71	1.1/16	29.63	2	50.80
		900	15	381.00	11.13/16	300.04	R45	12	1.1/8	28.58	1.1/8	28.58	5.1/16	128.59	1.3/16	30.16	2.3/16	55.56
		1500	15.1/2	393.70	10.15/16	277.81	R46	12	1.3/8	34.93	1.3/8	34.93	7.3/16	182.56	1.7/16	36.51	2.5/8	66.68
		2500	19	482.60	12.5/16	312.74	R47	8	2	50.80	2	50.80	9.3/16	233.36	2.1/16	52.39	2.3/4	69.85
8 200mm	8 200mm	150	13.1/2	342.90	10.13/16	274.64	R48	8	3/4	19.05	3/4	19.05	2.7/16	61.91	13/16	20.64	1.9/16	39.69
		300	15	381.00	11.15/16	303.21	R49	12	7/8	22.23	7/8	22.23	3.7/16	87.31	15/16	23.81	1.3/4	44.45
		400	15	381.00	11.13/16	300.04	R49	12	1	25.40	1	25.40	4.7/16	112.71	1.1/16	26.99	2	50.80
		600	16.1/2	419.10	12.7/16	315.91	R49	12	1.1/8	28.58	1.1/8	28.58	5.1/16	128.59	1.13/16	46.04	2.3/16	55.56
		900	18.1/2	469.90	13.15/16	354.01	R49	12	1.3/8	34.93	1.3/8	34.93	5.11/16	144.46	1.7/16	36.51	2.5/8	66.68
		1500	19	482.60	13.11/16	347.66	R50	12	1.5/8	41.28	1.5/8	41.28	7.15/16	201.61	1.11/16	42.86	3.1/16	77.79
		2500	21.3/4	552.45	16.1/16	407.99	R51	12	2	50.80	2	50.80	10.11/16	271.46	2.1/16	52.39	3.3/4	95.25
10 250mm	10 250mm	150	16	406.40	13.3/16	334.96	R52	12	7/8	22.23	7/8	22.23	22.9/16	65.09	15/16	23.81	1.3/4	44.45
		300	17.1/2	444.50	14.1/16	357.19	R53	16	1	25.40	1	25.40	3.15/16	100.01	1.1/16	26.99	2	50.80
		400	17.1/2	444.50	13.15/16	354.01	R53	16	1.1/8	28.58	1.1/8	28.58	4.15/16	125.41	1.3/16	30.16	2.3/16	55.56
		600	20	508.00	15.9/16	395.29	R53	16	1.1/4	31.75	1.1/4	31.75	5.11/16	144.46	1.5/16	33.34	2.7/16	61.91
		900	21.1/2	546.10	16.15/16	430.21	R53	16	1.3/8	34.93	1.3/8	34.93	6.3/16	157.16	1.7/16	36.51	2.5/8	66.68
		1500	23	584.20	16.15/16	430.21	R54	12	1.7/8	47.63	1.7/8	47.63	9.3/16	233.36	1.5/16	33.34	3.1/2	88.90
		2500	26.1/2	673.10	18.9/16	471.49	R55	12	2.1/2	63.50	2.1/2	63.50	13.11/16	347.66	2.9/16	65.09	4.5/8	117.48
12 300mm	12 300mm	150	19	482.60	15.15/16	404.81	R56	12	7/8	22.23	7/8	22.23	2.11/16	68.26	15/16	23.81	1.3/4	44.45
		300	20.1/2	520.70	16.7/16	417.51	R57	16	1.1/8	28.58	1.1/8	28.58	4.13/16	122.24	1.3/16	30.16	2.3/16	55.56
		400	20.1/2	520.70	16.5/16	414.34	R57	16	1.1/4	31.75	1.1/4	31.75	5.3/16	131.76	1.5/16	33.34	2.7/16	61.91
		600	22	558.80	17.13/16	452.44	R57	20	1.1/4	31.75	1.1/4	31.75	5.11/16	144.46	1.5/16	33.34	2.7/16	61.91
		900	24	609.60	19.7/16	493.71	R57	20	1.3/8	34.93	1.3/8	34.93	6.3/16	157.16	1.7/16	36.51	2.5/8	66.68
		1500	26.1/2	673.10	20.5/16	515.94	R58	16	2	50.80	2	50.80	10.7/16	265.11	2.1/16	52.39	3.3/4	95.25
		2500	30	762.00	21.7/16	544.51	R60	12	2.3/4	69.85	2.3/4	69.85	15.3/16	385.76	2.13/16	71.44	5.1/16	128.59
14 350mm	13.1/4 336.55 mm	150	21	533.40	17.9/16	446.09	R59	12	1	25.40	1	25.40	2.15/16	74.61	1.7/16	36.51	2	50.80
		300	23	584.20	18.15/16	481.01	R61	20	1.1/8	28.58	1.1/8	28.58	4.7/16	112.71	1.3/16	30.16	2.3/16	55.56
		400	23	584.20	18.13/16	477.84	R61	20	1.1/4	31.75	1.1/4	31.75	5.7/16	138.11	1.5/16	33.34	2.7/16	61.91
		600	23.3/4	603.25	19.3/16	487.36	R61	20	1.3/8	34.93	1.3/8	34.93	6.3/16	157.16	1.7/16	36.51	2.5/8	66.68
		900	25.1/4	641.35	20.5/16	515.94	R62	20	1.1/2	38.10	1.1/2	38.10	7.7/16	188.91	1.9/16	39.69	2.7/8	73.03
		1500	29.1/2	749.30	22.9/16	573.09	R63	16	2.1/4	57.15	2.1/4	57.15	11.3/16	284.16	2.5/16	58.74	4.3/16	106.36
16 400mm	15.14 387.35 mm	150	23.1/2	596.90	20.1/16	509.59	R64	16	1	25.40	1	25.40	3.1/16	77.79	1.1/16	26.99	2	50.80
		300	25.1/2	647.70	21.1/16	534.99	R64	20	1.1/4	31.75	1.1/4	31.75	4.11/16	119.06	1.7/16	36.51	2.7/16	61.90
		400	25.1/2	647.70	20.5/16	515.94	R65	20	1.3/8	34.93	1.3/8	34.93	5.11/16	144.46	1.7/16	36.51	2.5/8	66.68
		600	27	685.80	22.1/16	560.39	R65	20	1.1/2	38.10	1.1/2	38.10	6.11/16	169.86	1.9/16	39.69	2.7/8	73.03
		900	27.3/4	704.85	22.7/16	569.91	R66	20	1.5/8	41.28	1.5/8	41.28	7.11/16	195.26	1.11/16	42.86	3.1/16	77.79
		1500	32.1/2	825.50	25.1/16	636.59	R67	16	2.1/2	63.50	2.1/2	63.50	12.3/16	309.56	2.9/16	65.09	4.5/8	117.48
18 450mm	2.1/2 65mm	150	25	635.00	21.7/16	544.51	R68	16	1.1/8	28.58	1.1/8	28.58	3.5/16	84.14	1.3/16	30.16	2.3/16	55.56
		300	28	711.20	23.5/16	592.14	R69	24	1.1/4	31.75	1.1/4	31.75	4.15/16	125.41	1.5/16	33.34	2.7/16	61.91
		400	28	711.20	23.3/16	588.96	R69	24	1.3/8	34.93	1.3/8	34.93	5.15/16	150.81	1.7/16	36.51	2.5/8	66.68
		600	29.1/4	742.95	23.15/16	608.01	R69	20	1.5/8	41.28	1.5/8	41.28	7.3/16	182.56	1.11/16	42.86	3.1/16	77.79
		900	31	787.40	24.15/16	633.41	R70	20	1.7/8	47.63	1.7/8	47.63	8.11/16	220.66	1.15/16	49.21	3.1/2	88.90
		1500	36	914.40	27.9/16	700.09	R71	16	2.3/4	69.85	2.3/4	69.85	13.7/16	341.31	2.13/16	71.34	5.1/16	128.59
20 500mm	3 80mm	150	27.1/2	698.50	23.11/16	601.66	R72	20	1.1/8	28.58	1.1/8	28.58	3.9/16	90.49	1.3/16	30.16	2.3/16	55.56
		300	30.1/2	774.70	25.9/16	649.22	R73	24	1.1/4	31.75	1.1/4	31.75	5.3/16	131.76	1.5/16	33.34	2.7/16	61.91
		400	30.1/2	774.70	25.5/16	642.94	R73	24	1.1/2	38.10	1.1/2	38.10	6.3/16	157.16	1.9/16	39.69	2.7/8	73.03
		600	32	812.80	26.11/16	677.86	R73	24	1.5/8	41.28	1.5/8	41.28	7.11/16	195.26	1.11/16	42.86	3.1/16	77.79
		900	33.3/4	857.25	27.5/16	693.74	R74	20	2	50.80	2	50.80	9.3/16	233.36	2.1/16	52.39	2.3/4	69.85
		1500	38.3/4	984.25	29.9/16	750.89	R75	16	3	76.20	3	76.20	14.11/16	373.06	3.1/16	77.79	5.1/2	139.70
24 600mm	3.1/2 90mm	150	32	812.80	28.1/16	712.79	R76	20	1.1/4	31.75	1.1/4	31.75	3.15/16	100.01	1.5/16	33.34	2.7/16	61.91
		300	36	914.40	30.5/16	769.94	R77	24	1.1/2	38.10	1.1/2	38.10	5.11/16	144.46	1.9/16	39.69	2.7/8	73.03
		400	36	914.40	30.1/16	763.59	R77	24	1.3/4	44.45	1.3/4	44.45	6.11/16	169.86	1.13/16	46.04	3.5/16	84.14
		600	37	939.80	30.15/16	785.81	R77	24	1.7/8	47.63	1.7/8	47.63	8.11/16	220.66	1.15/16	49.21	3.1/2	88.90
		900	41	1041.40	32.13/16	833.44	R78	20	2.1/2	63.50	2.1/2	63.50	11.11/16	296.86	2.9/16	65.09	4.5/8	117.48
		1500	46	1168.40	35.5/16	896.94	R79	16	3.1/2	88.90	3.1/2	88.90	16.11/16	423.86	3.9/16	90.49	6.3/8	161.93

根據ASME B16.21

適用於ANSI B16.5法蘭

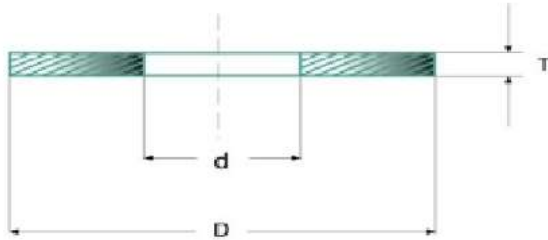

單位:mm

RF							
法蘭尺寸	內徑 d	150#	300#	400#	600#	900#	1500#
	D						
1/2"	21	48	54	54	54	64	64
3/4"	27	57	67	67	67	70	70
1"	33	67	73	73	73	79	79
1-1/4"	42	76	83	83	83	89	89
1-1/2"	48	86	95	95	95	98	98
2"	60	105	111	111	111	143	143
2-1/2"	73	124	130	130	130	165	165
3"	89	137	149	149	149	168	175
3-1/2"	102	162	165	162	162	-	-
4"	114	175	181	178	194	206	210
5"	141	197	216	213	241	248	254
6"	168	222	251	248	267	289	283
8"	219	279	308	305	321	359	352
10"	273	340	362	359	400	435	435
12"	324	410	422	419	457	498	521
14"	356	451	486	483	492	521	578
16"	406	514	540	537	565	575	641
18"	457	549	597	594	613	638	705
20"	508	606	654	648	683	699	756
24"	610	718	755	768	791	838	902

根據ASME B16.21

適用於ANSI B16.5法蘭

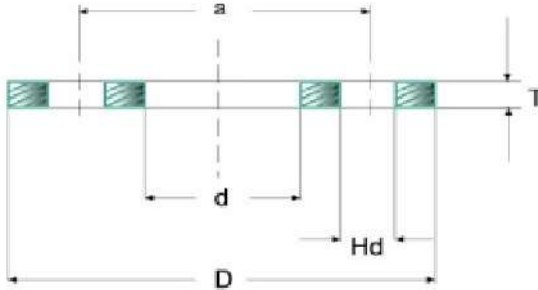

單位:mm

FF										
法蘭 尺寸	150#					300#				
	d	D	線徑 a	孔徑 Hd	孔數	d	D	線徑 a	孔徑 Hd	孔數
1/2"	21	89	60.3	16	4	21	95	66.7	16	4
3/4"	27	98	69.9	16	4	27	117	82.6	19	4
1"	33	108	79.4	16	4	33	124	88.9	19	4
1-1/4"	42	117	88.9	16	4	42	133	98.4	19	4
1-1/2"	48	127	98.4	16	4	48	156	114.3	22	4
2"	60	152	120.7	19	4	60	165	127.0	19	8
2-1/2"	73	178	139.7	19	4	73	191	149.2	22	8
3"	89	191	152.4	19	4	89	210	168.3	22	8
3-1/2"	102	216	177.8	19	8	102	229	184.2	22	8
4"	114	229	190.5	19	8	114	254	200.0	22	8
5"	141	254	215.9	22	8	141	279	235.0	22	8
6"	168	279	241.3	22	8	168	318	269.9	22	12
8"	219	343	298.5	22	8	219	381	330.2	25	12
10"	273	406	362	25	12	273	445	387.4	29	16
12"	324	483	431.8	25	12	324	521	450.9	32	16
14"	356	533	476.3	29	12	356	584	514.4	32	20
16"	406	597	539.8	29	16	406	648	571.5	35	20
18"	457	635	577.9	32	16	457	711	628.7	35	24
20"	508	699	635.0	32	20	508	774	685.8	35	24
24"	610	813	749.3	35	20	610	914	812.8	42	24

根據ASME B16.21

適用於 ANSI B16.47 Series A (MSSP44) & Series B (API 605)法蘭

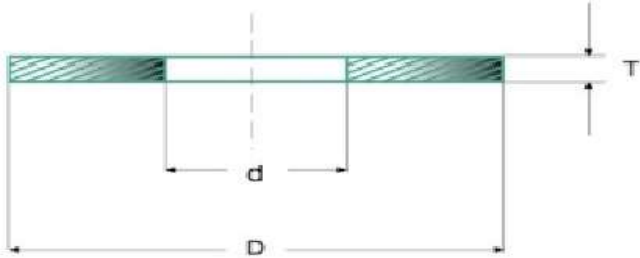

單位:mm

法蘭 尺寸	SERIES B(API 605) RF						SERIES A (MSS-SP44) RF					
	內徑	75#	150#	300#	400#	600#	內徑	150#	300#	400#	600#	900#
	d	D					d	D				
22"	-	-	-	-	-	-	559	660	705	702	733	-
26"	660	708	725	772	746	765	660	775	835	832	867	879
28"	711	759	776	826	800	819	771	832	899	892	914	943
30"	762	810	827	888	857	879	762	883	953	946	972	1007
32"	813	860	881	940	911	933	813	940	1006	1003	1022	1070
34"	864	911	935	994	962	997	864	991	1057	1054	1073	1134
36"	914	973	987	1048	1022	1048	914	1048	1118	1118	1130	1197
38"	965	1024	1045	1099	-	-	965	1111	1054	1073	1105	1197
40"	1016	1075	1095	1149	-	-	1016	1162	1114	1127	1156	1248
42"	1067	1126	1146	1200	-	-	1067	1219	1165	1178	1219	1299
44"	1118	1181	1197	1251	-	-	1118	1276	1219	1232	1270	1365
46"	1168	1232	1256	1318	-	-	1168	1327	1273	1289	1327	1432
48"	1219	1283	1307	1368	-	-	1219	1384	1324	1346	1391	1483
50"	1270	1334	1357	1419	-	-	1270	1435	1378	1403	1448	-
52"	1321	1384	1408	1470	-	-	1321	1492	1429	1454	1499	-
54"	1372	1438	1464	1530	-	-	1372	1549	1492	1518	1556	-
56"	1422	1495	1514	1594	-	-	1422	1607	1543	1588	1513	-
58"	1473	1546	1580	1656	-	-	1473	1664	1594	1619	1664	-
60"	1524	1597	1630	1705	-	-	1524	1715	1645	1683	1721	-

根據 JIS B 2404:2006

適用於 JIS B 2220, B 2238, B 2239, B 2240, B 2241 法蘭

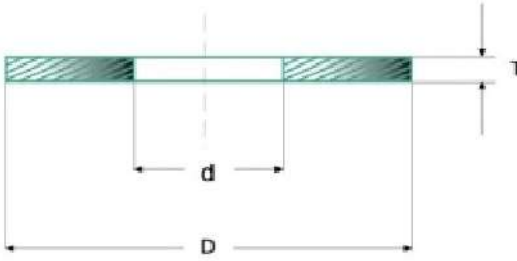

單位:mm

法蘭 尺寸	RF						
	內徑	2K	5K	10K	16K	20K	30K
	d	D					
10	18	-	45	53	53	53	59
15	22	-	50	58	58	58	64
20	28	-	55	63	63	63	69
25	35	-	65	74	74	74	79
32	43	-	78	84	84	84	89
40	49	-	83	89	89	89	100
50	61	-	93	104	104	104	114
65	84	-	118	124	124	124	140
80	90	-	129	134	140	140	150
90	102	-	139	144	150	150	163
100	115	-	149	159	165	165	173
125	141	-	184	190	203	203	208
150	167	-	214	220	238	238	251
175	192	-	240	245	-	-	-
200	218	-	260	270	283	283	296
225	244	-	285	290	-	-	-
250	270	-	325	333	356	356	360
300	321	-	370	378	406	406	420
350	359	-	413	423	450	450	465
400	410	-	473	486	510	510	524
450	460	535	533	541	575	575	-
500	513	585	583	596	630	630	-
550	564	643	641	650	684	684	-
600	615	693	691	700	734	734	-
650	667	748	746	750	784	805	-
700	718	798	796	810	836	855	-
750	770	856	850	870	896	918	-
800	820	906	900	920	945	978	-
850	872	956	950	970	995	1038	-
900	923	1006	1000	1020	1045	1088	-
1000	1025	1106	1100	1124	1158	-	-
1100	1130	1216	1210	1234	1258	-	-
1200	1230	1326	1320	1344	1368	-	-
1350	1385	1481	1475	1498	1534	-	-
1500	1540	1636	1630	1658	1694	-	-

根據 JIS B 2404:2006

適用於 JIS B 2220, B 2238, B 2239, B 2240, B 2241 法蘭

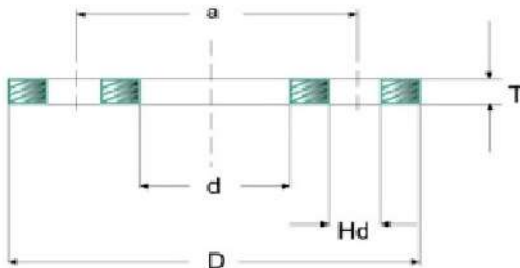

單位:mm

法尺	內徑	FF															
		2K				5K				10K				16K			
DN	d	a	D	孔徑 Hd	孔數	a	D	孔徑 Hd	孔數	a	D	孔徑 Hd	孔數	a	D	孔徑 Hd	孔數
10	18	-	-	-	-	55	75	12	4	65	90	15	4	65	90	15	4
15	22	-	-	-	-	60	80	12	4	70	95	15	4	70	95	15	4
20	28	-	-	-	-	65	85	12	4	75	100	15	4	75	100	15	4
25	35	-	-	-	-	75	95	12	4	90	125	19	4	90	125	19	4
32	43	-	-	-	-	90	115	15	4	100	135	19	4	100	135	19	4
40	49	-	-	-	-	95	120	15	4	105	140	19	4	105	140	19	4
50	61	-	-	-	-	105	130	15	4	120	155	19	4	120	155	19	8
65	84	-	-	-	-	130	155	15	4	140	175	19	4	140	175	19	8
80	90	-	-	-	-	145	180	19	4	150	185	19	8	160	200	23	8
90	120	-	-	-	-	155	190	19	4	160	195	19	8	170	210	23	8
100	115	-	-	-	-	165	200	19	8	175	210	19	8	185	225	23	8
125	141	-	-	-	-	200	235	19	8	210	250	23	8	225	270	25	8
150	167	-	-	-	-	230	265	19	8	240	280	23	8	260	305	25	12
175	192	-	-	-	-	260	300	23	8	265	305	23	12	-	-	-	-
200	218	-	-	-	-	280	325	23	8	290	330	23	12	305	350	25	12
225	244	-	-	-	-	305	345	23	12	310	350	23	12	-	-	-	-
250	270	-	-	-	-	345	385	23	12	355	400	25	12	380	430	27	12
300	321	-	-	-	-	390	430	23	12	400	445	25	16	430	480	27	16
350	359	-	-	-	-	435	480	25	12	445	490	25	16	480	540	33	16
400	410	-	-	-	-	495	540	25	16	510	560	27	16	540	605	33	16
450	460	555	605	23	16	555	605	25	16	565	620	27	20	605	675	33	20
500	513	605	655	23	20	605	655	25	20	620	675	27	20	660	730	33	20
550	564	665	720	25	20	665	720	27	20	680	745	33	20	720	795	39	20
600	615	715	770	25	20	715	770	27	20	730	795	33	24	770	845	39	24
650	667	770	825	25	24	770	825	27	24	780	845	33	24	-	-	-	-
700	718	820	875	25	24	820	875	27	24	840	905	33	24	-	-	-	-
750	770	880	945	27	24	880	945	33	24	900	970	33	24	-	-	-	-
800	820	930	995	27	24	930	995	33	24	950	###	33	28	-	-	-	-
850	872	980	###	27	24	980	###	33	24	###	###	33	28	-	-	-	-
900	923	###	###	27	24	###	###	33	24	###	###	33	28	-	-	-	-
###	###	###	###	27	28	###	###	33	28	###	###	39	28	-	-	-	-
###	###	###	###	27	28	###	###	33	28	###	###	39	28	-	-	-	-
###	###	###	###	27	32	###	###	33	32	###	###	39	32	-	-	-	-
###	###	###	###	27	32	###	###	33	32	###	###	45	36	-	-	-	-
###	###	###	###	27	36	###	###	33	36	###	###	45	40	-	-	-	-



王利企業有限公司
ONE LEVEL Ltd.

812 高雄市小港區高鳳路 221 號

Tel: 07-7914999

Fax: 07-7914777

Email: onelevel@onelevel.com.tw

